

A2FO (ISO) Bent Axis Pumps -2022-

ISO Mounting Flange High Pressure Bent Axis Pump

High Pressure Hydraulic Bent Axis Piston Pumps, High Pressure, 350/400 BAR Working Pressure. High Rotational Speed, High Efficiency, Slim Design, Cast Iron Pump Body, Re-Designed in 2022.

Designation;

5cc, 10cc, 12cc, 18cc, 25cc, 32cc, 41cc, 50cc,
56cc, 63cc, 80cc, 108cc, 125cc, 160cc, 180cc

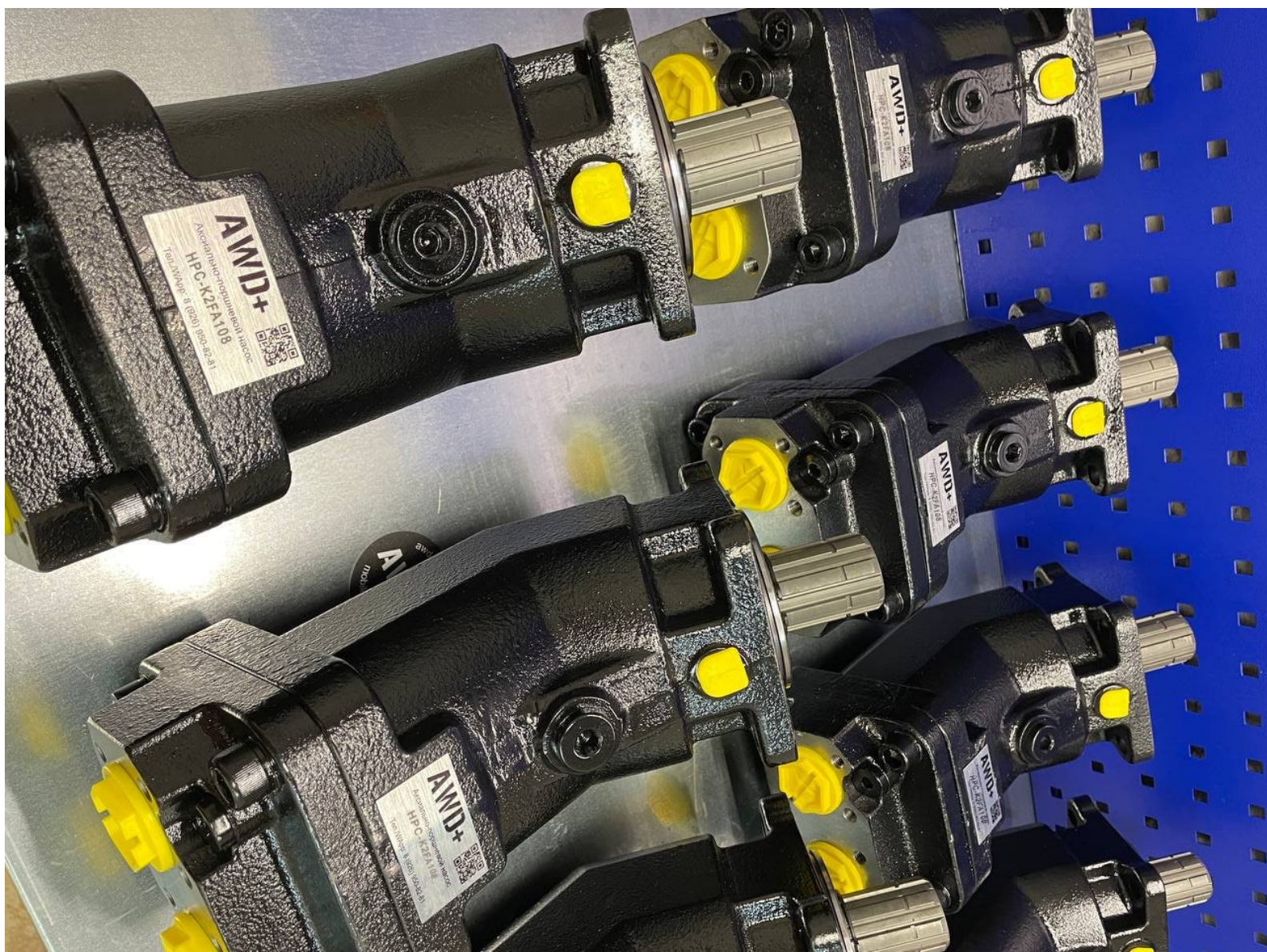

Index

Cover	1
Index.....	2
A2FO Pumps.....	3
Ordering Code of A2FO Pumps.....	4
A2FO - 5 cc (ISO) Bent Axis Pump.....	5
A2FO - 10 cc (ISO) Bent Axis Pump.....	6
A2FO - 12 cc (ISO) Bent Axis Pump.....	7
A2FO - 18 cc (ISO) Bent Axis Pump.....	8
A2FO - 25 cc (ISO) Bent Axis Pump.....	9
A2FO - 32 cc (ISO) Bent Axis Pump.....	11
A2FO - 41 cc (ISO) Bent Axis Pump.....	13
A2FO - 45 cc (ISO) Bent Axis Pump.....	15
A2FO - 50 cc (ISO) Bent Axis Pump.....	17
A2FO - 56 cc (ISO) Bent Axis Pump.....	19
A2FO - 63 cc (ISO) Bent Axis Pump.....	21
A2FO - 80 cc (ISO) Bent Axis Pump.....	23
A2FO - 90 cc (ISO) Bent Axis Pump.....	25
A2FO - 108 cc (ISO) Bent Axis Pump.....	27
A2FO - 125 cc (ISO) Bent Axis Pump.....	29
A2FO - 160 cc (ISO) Bent Axis Pump.....	31
A2FO - 180 cc (ISO) Bent Axis Pump.....	33
Special Shaft Drive.....	35
Direction of Rotation.....	36
Installation and Assemble Information.....	37
Formulas, Calculations.....	38
Complete Product Range.....	39
Contact Information.....	40

Characteristics of the A2FO - ISO Flange Bent Axis Pumps

Pump MODEL	DISPL. (cc)	CONTINUOUS MAX. SPEED (rpm)	INTERMITTENT MAX. SPEED (rpm)	MAX. FLOW ABSORBED (l/mn)	TORQUE BAR (m.N/bar)	TORQUE AT 350 BAR (m.N)	THEORETICAL MAX. POWER AT 400 BAR (HP / kW)	MAX. ALLOW PRESSURE CONTN./PEAK (bar)	WEIGHT (kg)
5 cc	5.1	8800	9600	45	0.09	46	64.1 / 48.2	400 / 450	5.2
10 cc	10.2	8600	9400	88	0.14	58	72.9 / 54.4	400 / 450	5.5
12 cc	12.0	8000	8800	96	0.19	67	85.5 / 64.4	400 / 450	5.5
18 cc	18.0	8000	8800	144	0.28	99	128.5 / 95.9	400 / 450	5.5
25 cc	25.0	6300	6900	158	0.40	139	140.0 / 104.4	400 / 450	11.4
32 cc	32.0	6300	6900	202	0.50	178	180.5 / 134.4	400 / 450	11.5
41 cc	41.0	5600	6200	230	0.65	228	205.2 / 153.1	400 / 450	11.6
45 cc	45.0	5600	6200	252	0.72	253	202.4 / 151.8	400 / 450	17.9
50 cc	50,3	5000	5500	252	0.80	280	224.1 / 167.5	400 / 450	18.1
56 cc	56,0	5000	5500	280	0.90	320	244.5 / 187.1	400 / 450	18.1
63 cc	63.0	5000	5500	315	1.00	351	281.6 / 209.1	400 / 450	18.2
80 cc	80,4	4500	5000	362	1.27	447	323.6 / 241.5	400 / 450	23.1
90 cc	90,1	4500	5000	405	1.43	500	361.5 / 269.9	400 / 450	23.2
108 cc	108	4000	4400	435	1.70	598	328.8 / 245.6	400 / 450	35.2
125 cc	125	3400	4400	428	2.00	698	382.6 / 284.6	400 / 450	38.8
160 cc	160	3400	4000	486	2.55	890	514.6 / 383.9	400 / 450	48.6
180 cc	180	3400	4000	612	2.86	1004	581.2 / 433.6	400 / 450	52.6

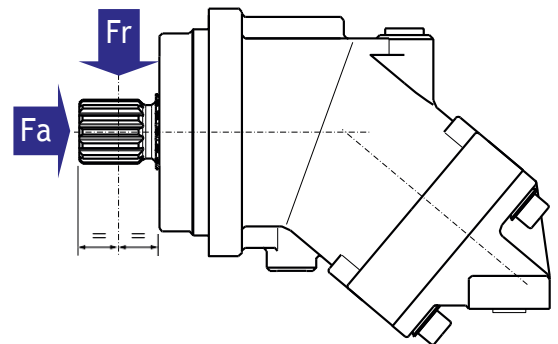

Pump model	5, 10, 12	18 cc	25 cc	32 cc	41. 45	50 cc	56, 63cc	80,90,108	125 cc	160, 180
Fr (lbf)	630	900	1350	1462.5	1462.5	1686	2023	2812	3262	4500
Fr (N/bar)	2800	4000	6000	6500	6500	7500	9000	12500	14500	20000
Fa (lbf)	0.23	0.31	0.42	0.46	0.62	0.62	0.77	1.24	1.33	1.47
Fa (N/bar)	(15)	(20)	(27)	(30)	(40)	(40)	(50)	(80)	(86)	(95)

Ordering Code; A2FO - ISO Flange Bent Axis Pumps

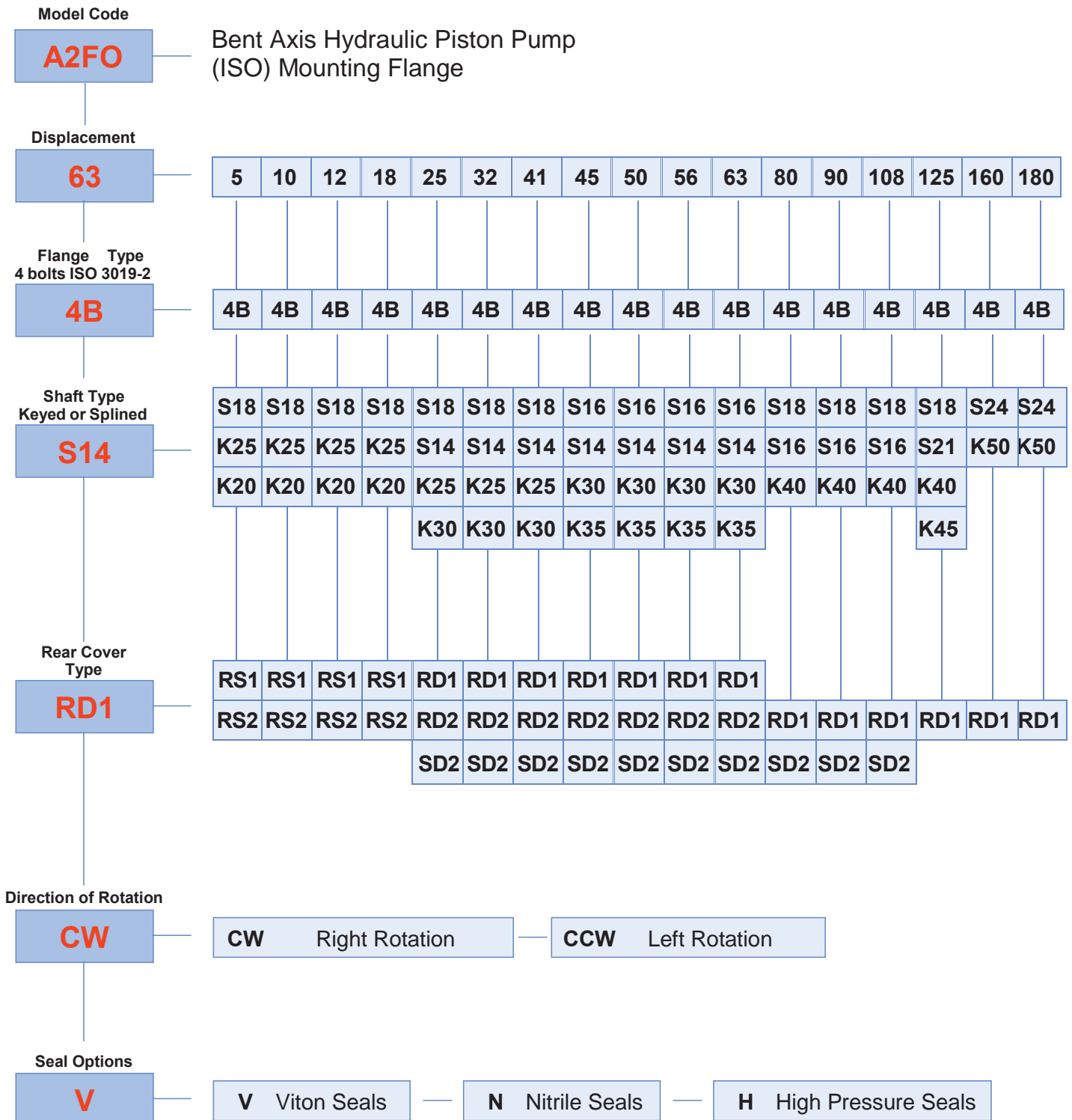

A2FO - 5 cc (ISO) Bent Axis Pump

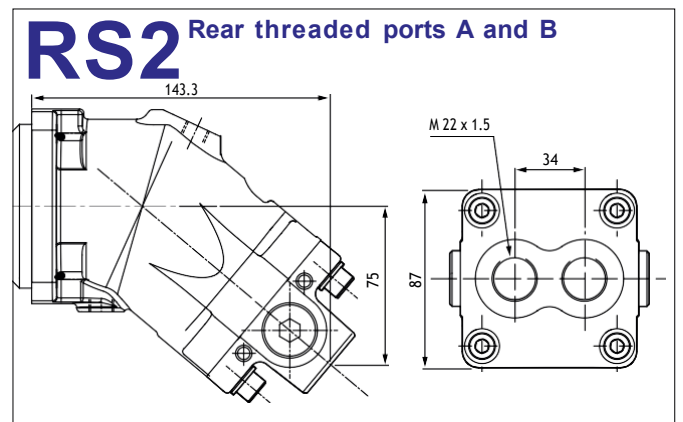
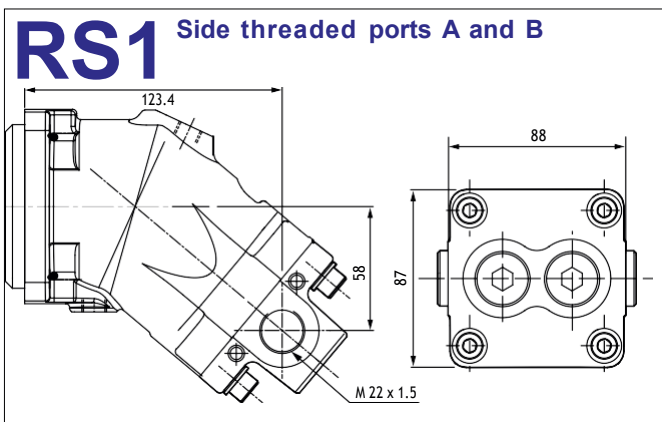
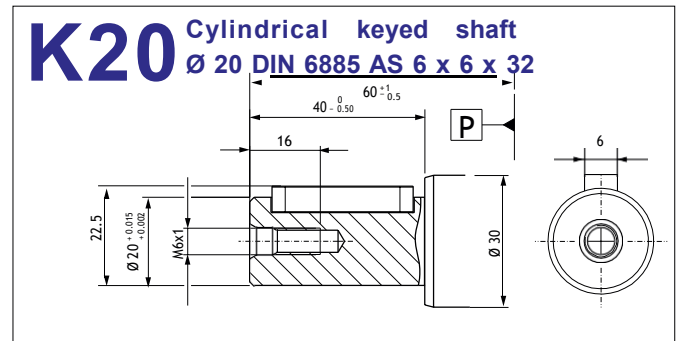
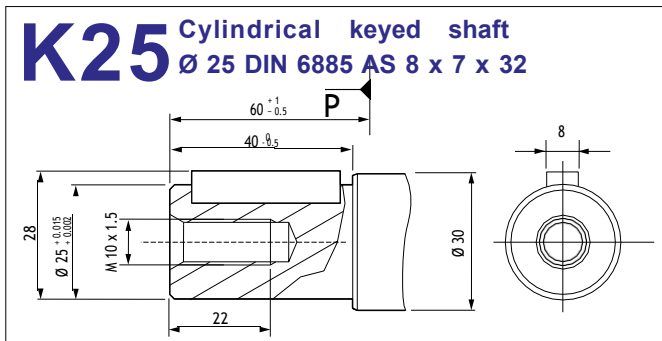
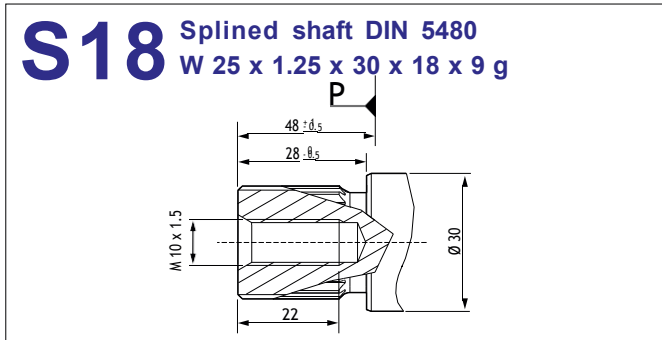
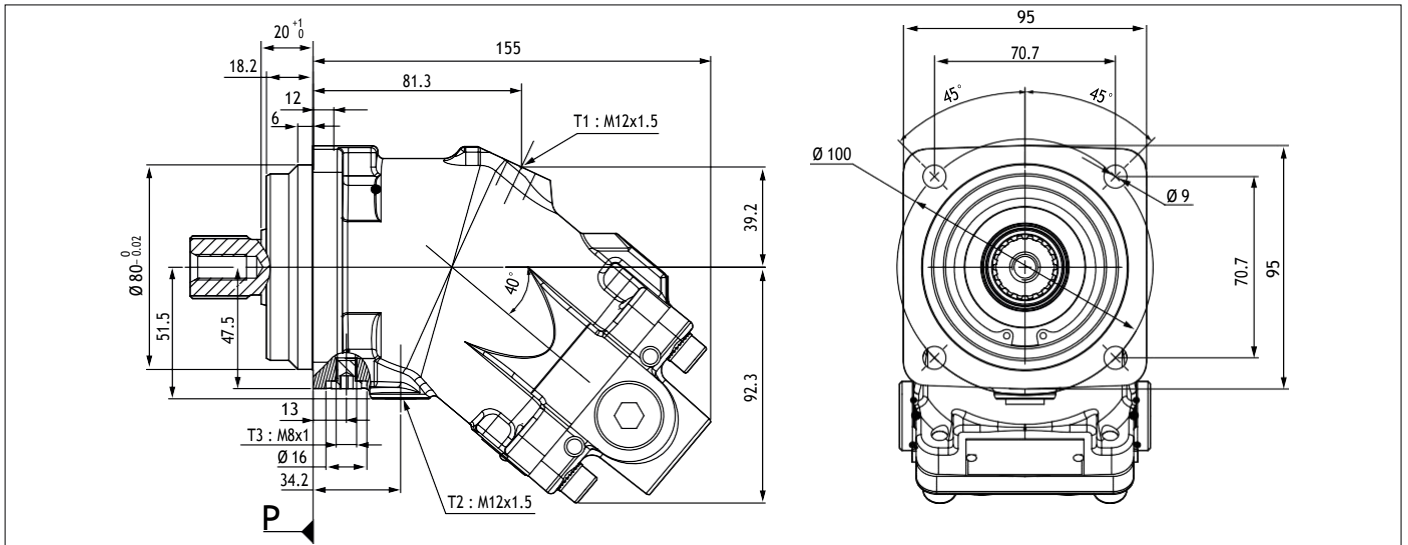

A2FO - 10 cc (ISO) Bent Axis Pump

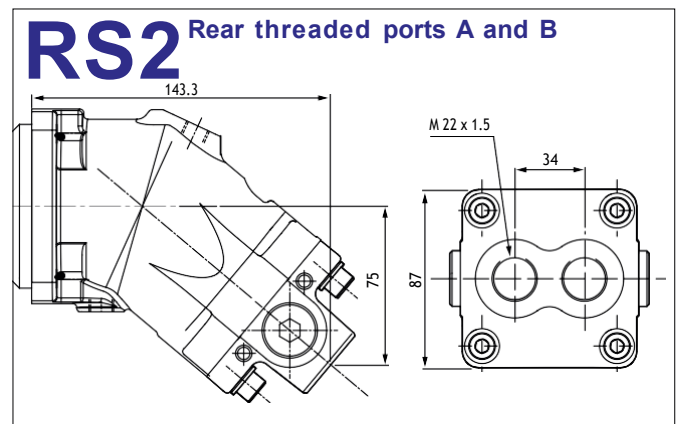
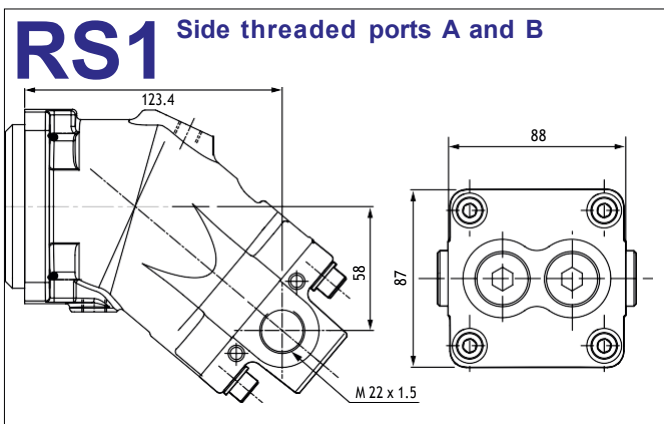
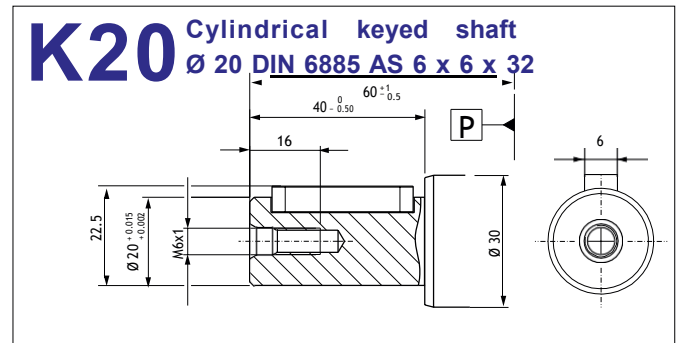
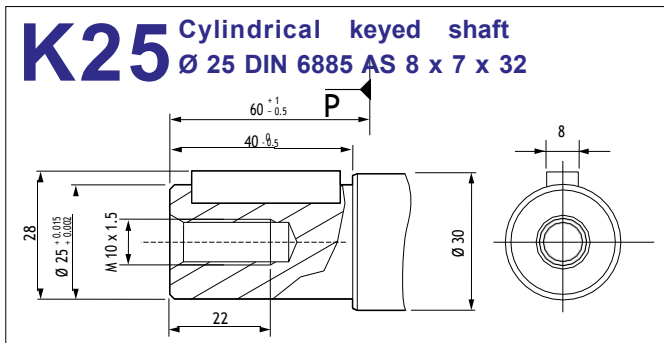
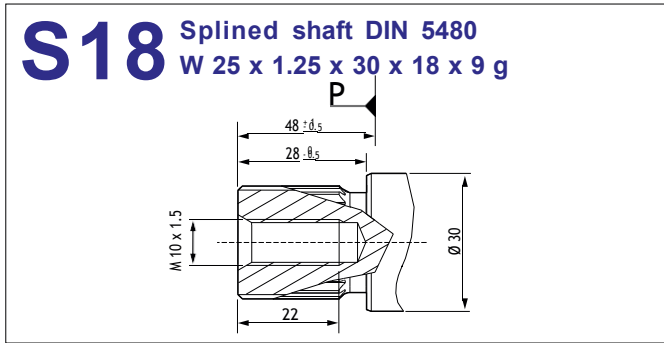
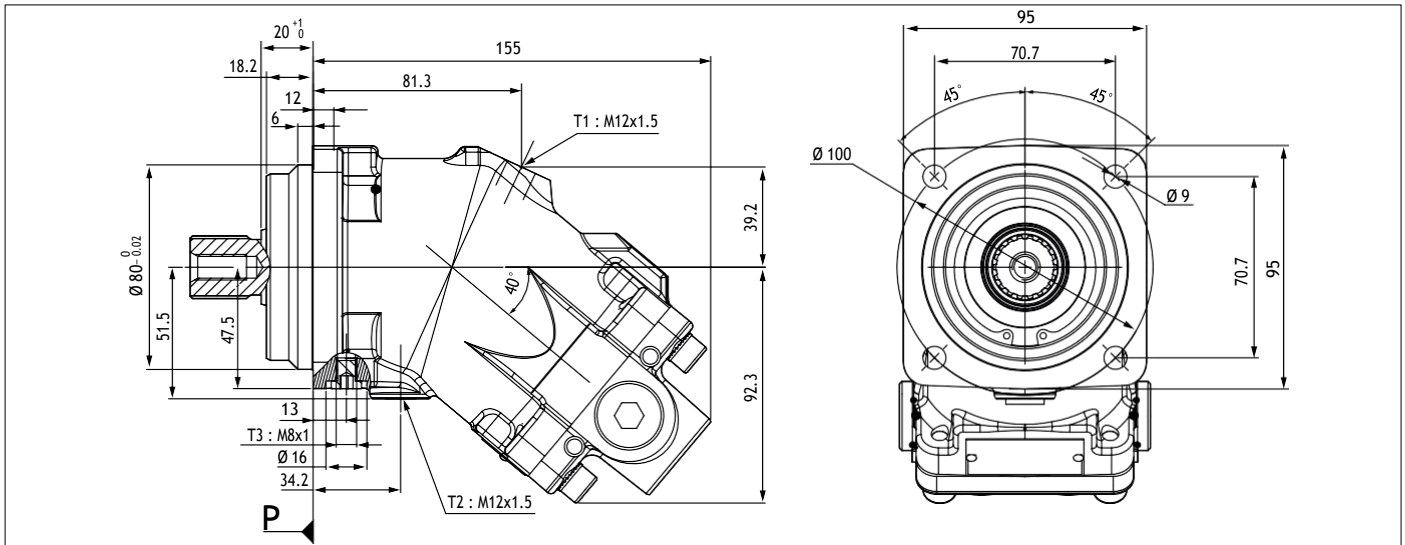

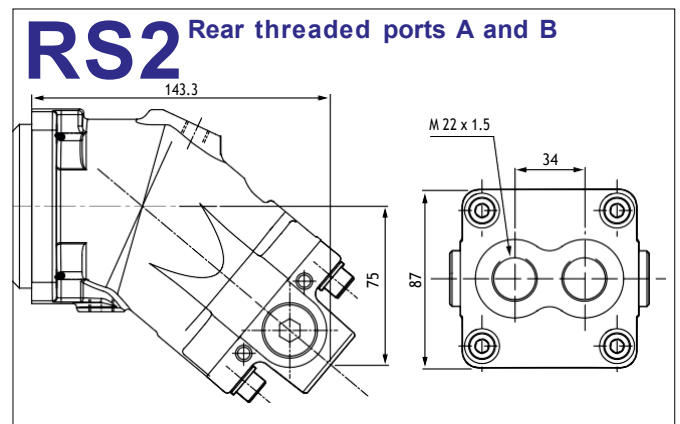
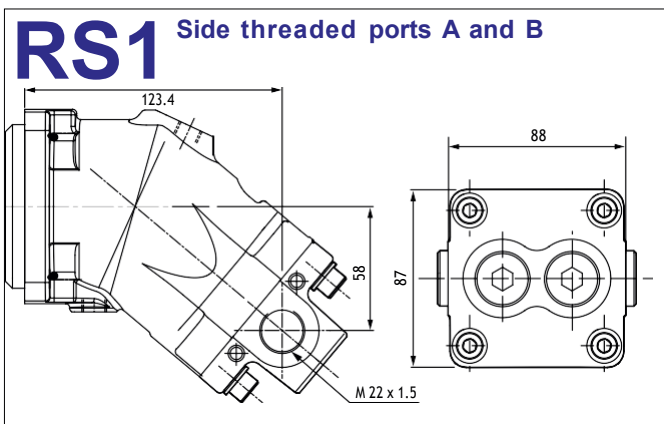
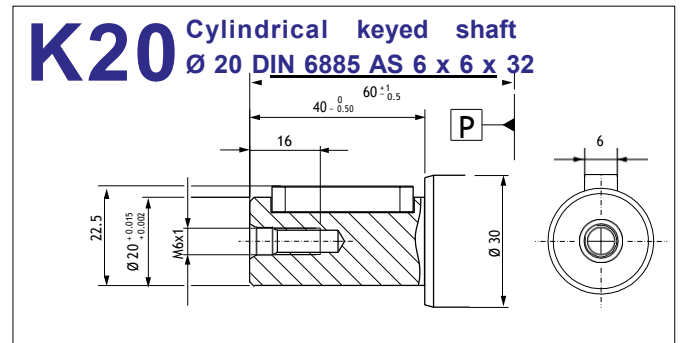
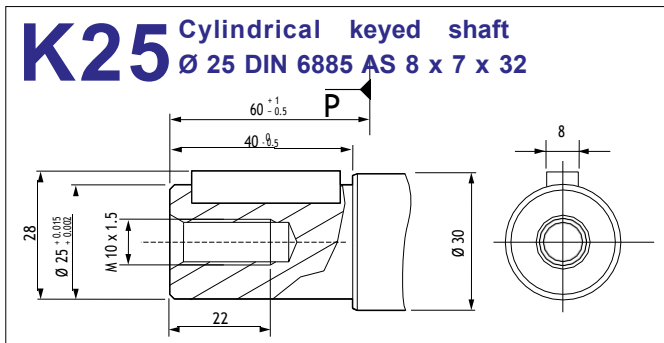
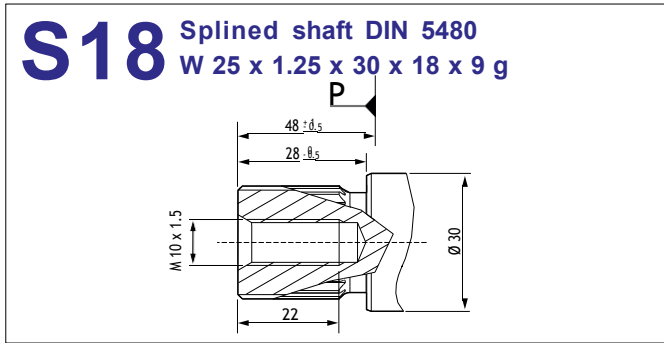
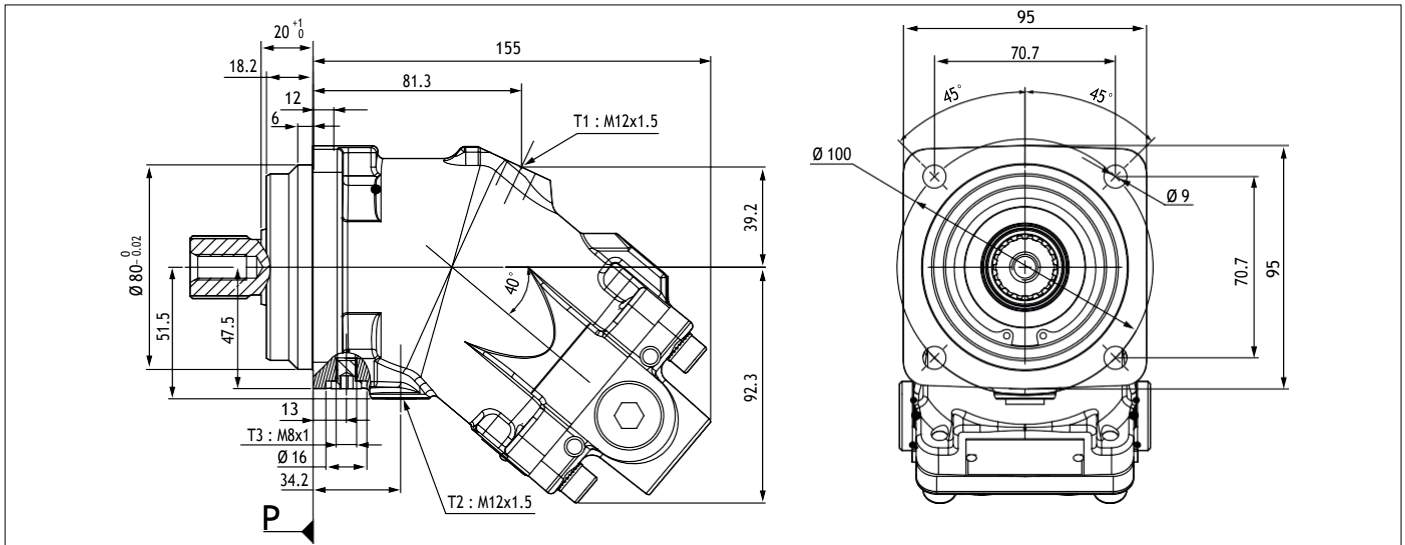

A2FO - 18 cc (ISO) Bent Axis Pump

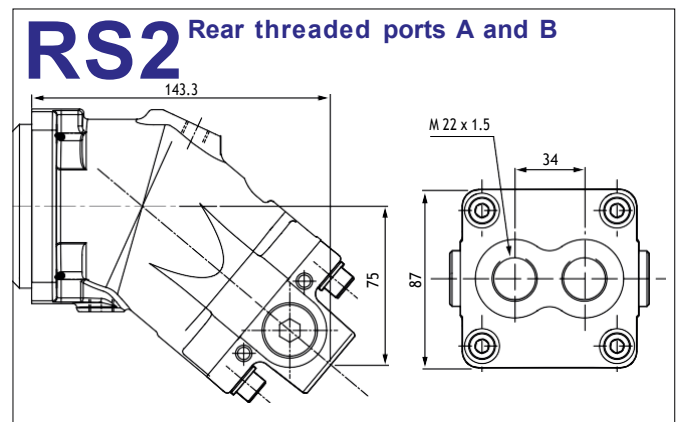
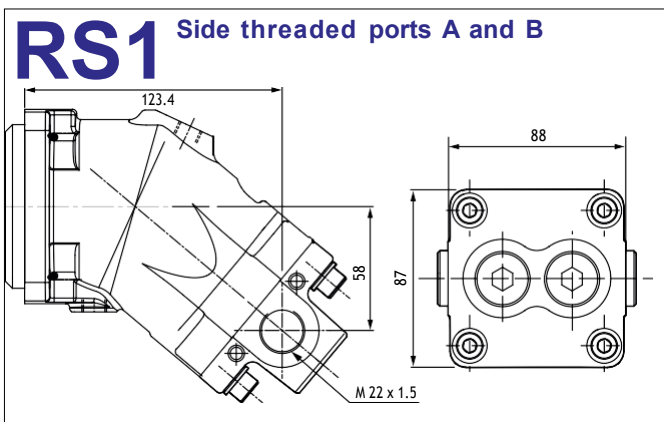
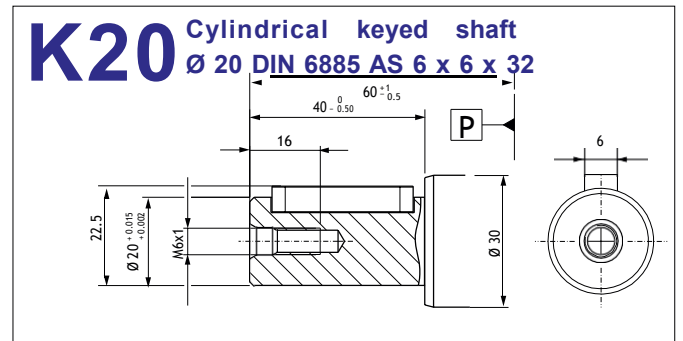
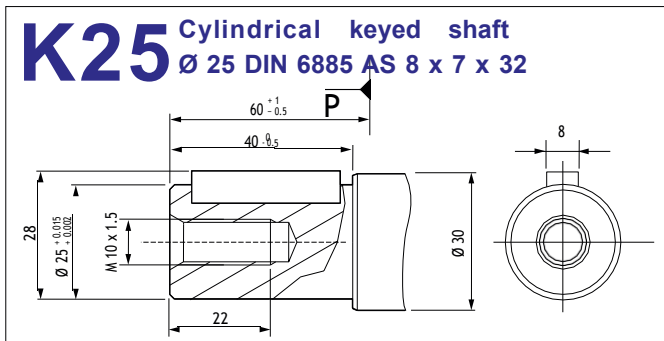
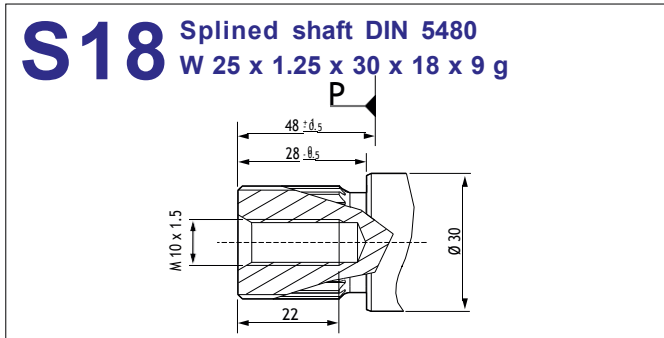
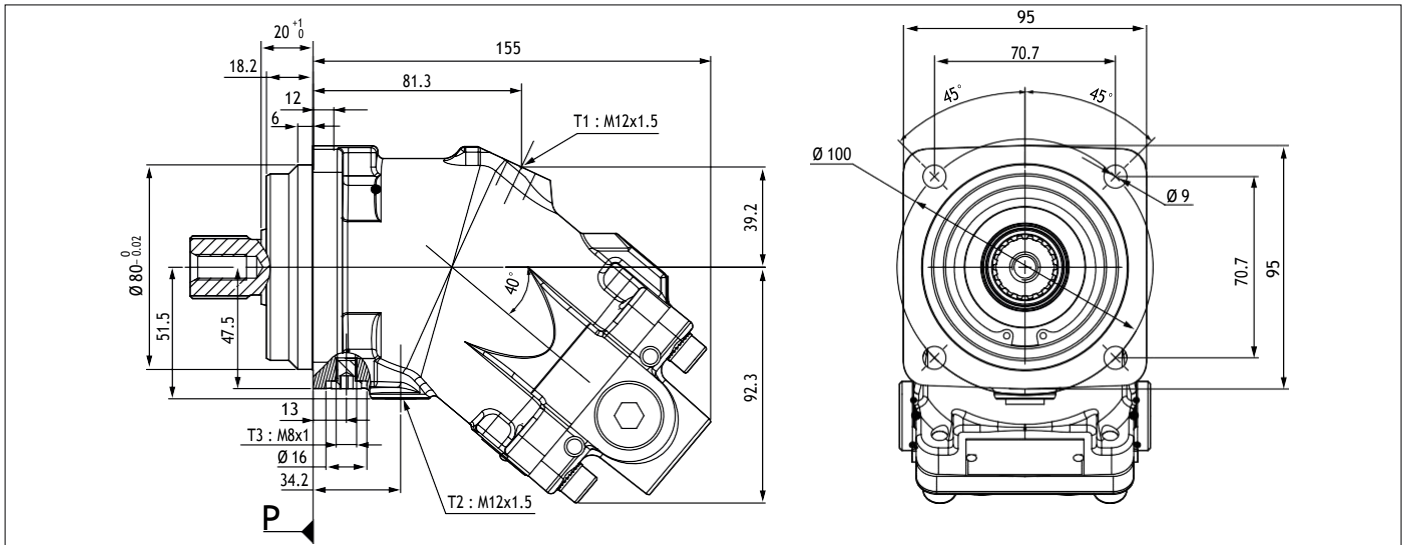

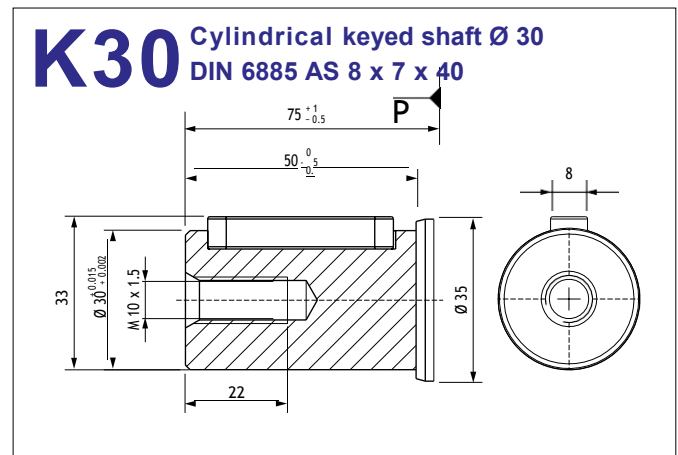
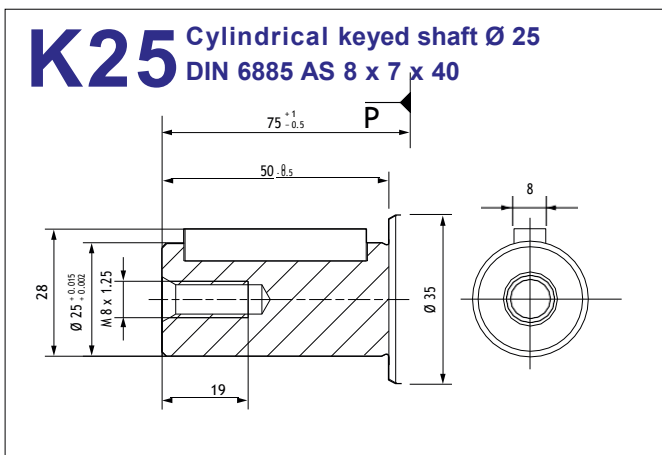
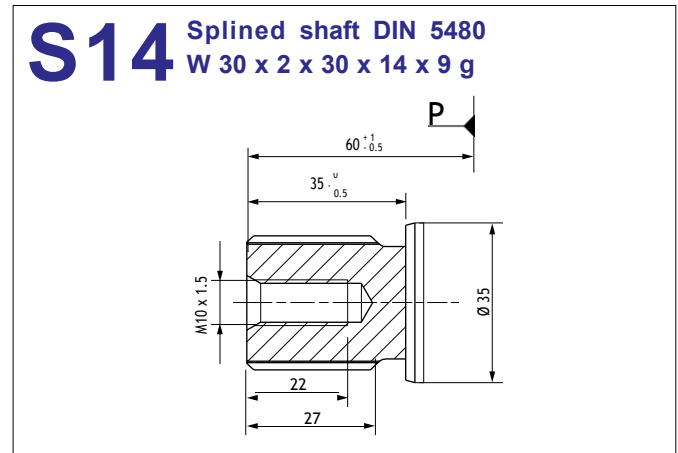
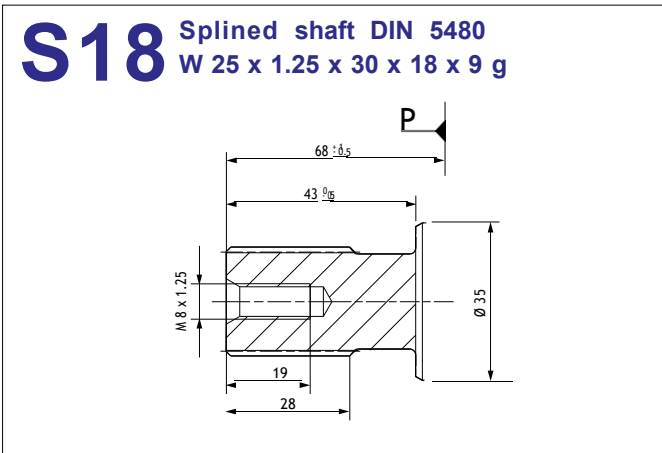
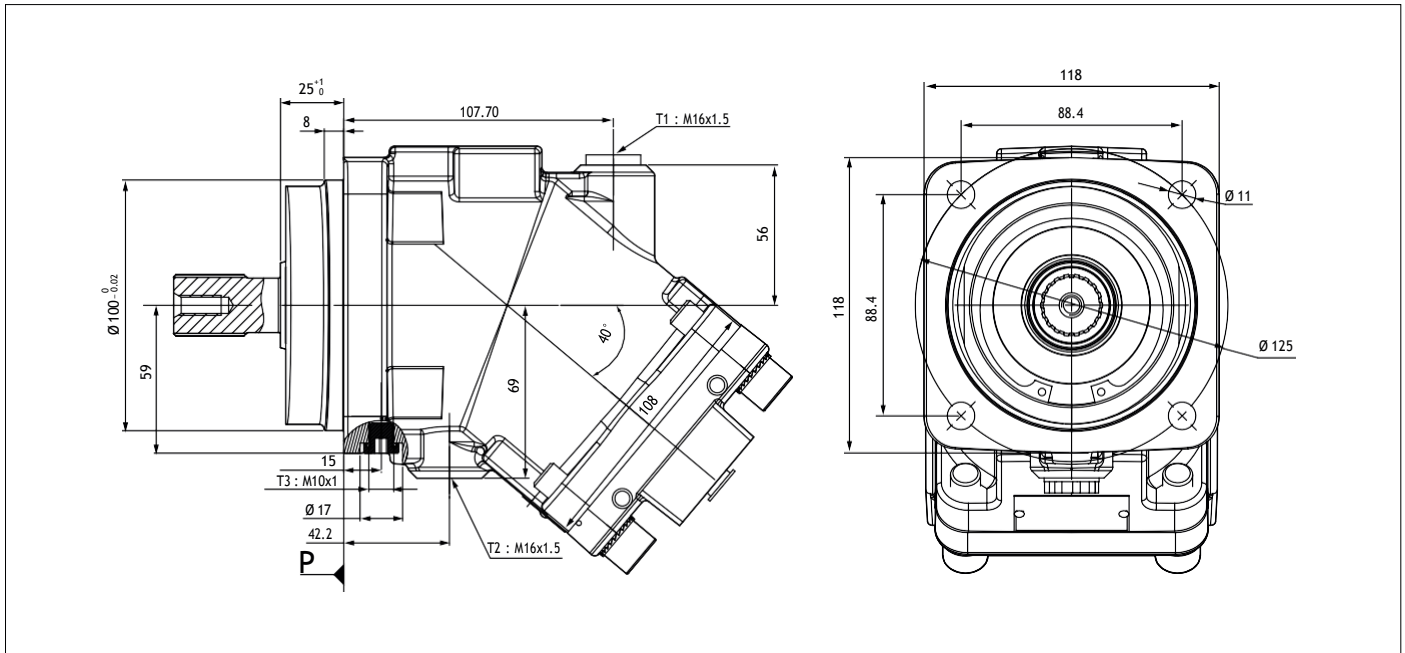

A2FO - 25 cc (ISO) Bent Axis Pump

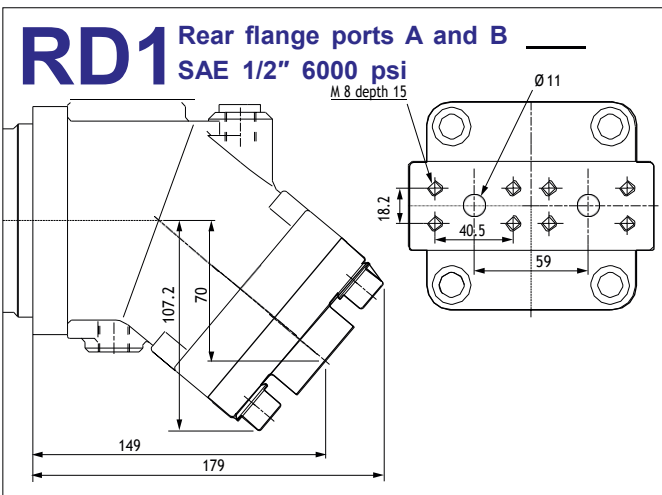
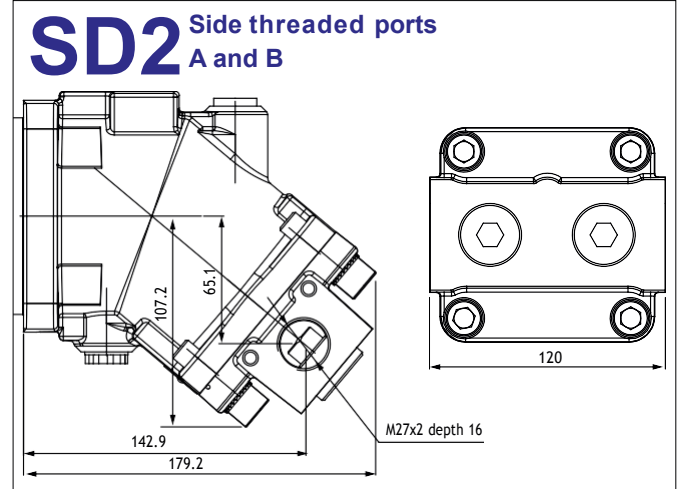
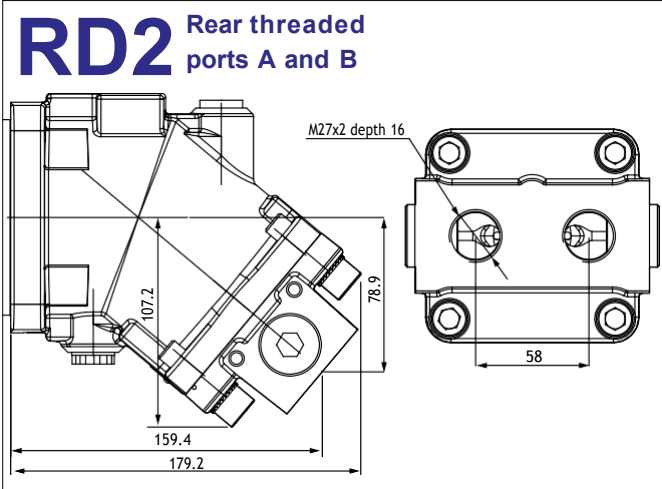

A2FO - 32 cc (ISO) Bent Axis Pump

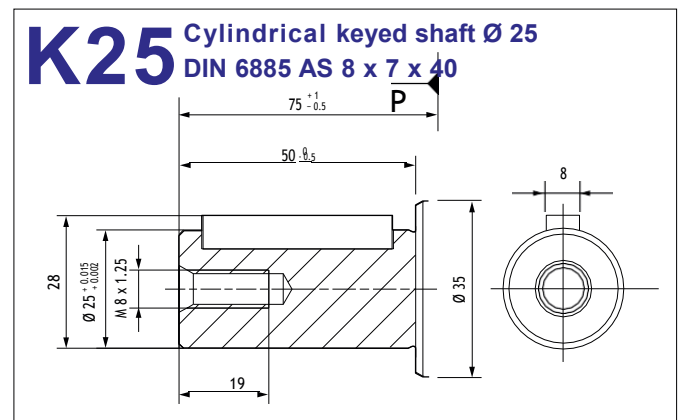
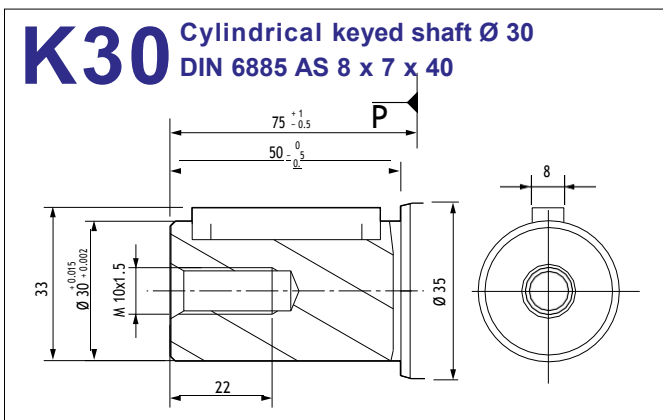
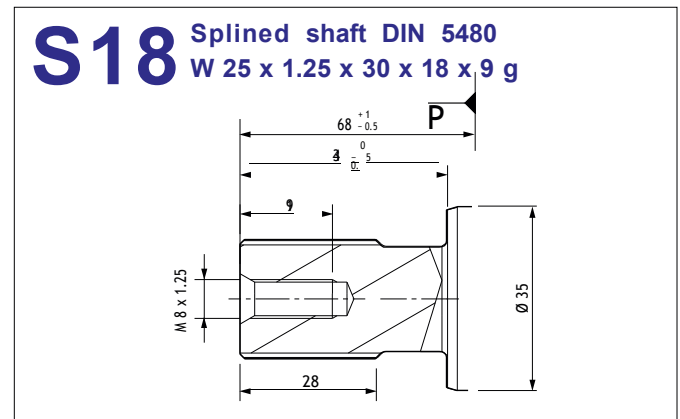
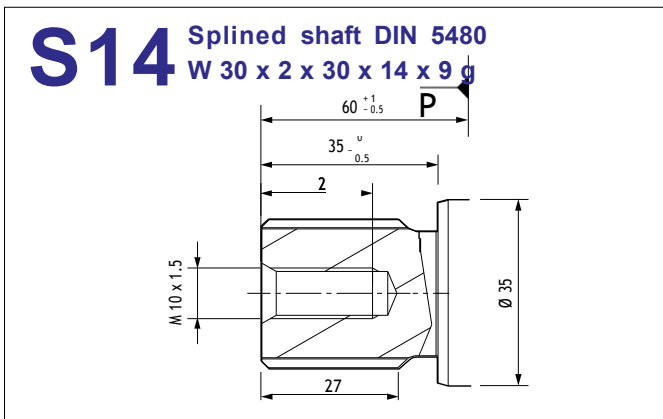
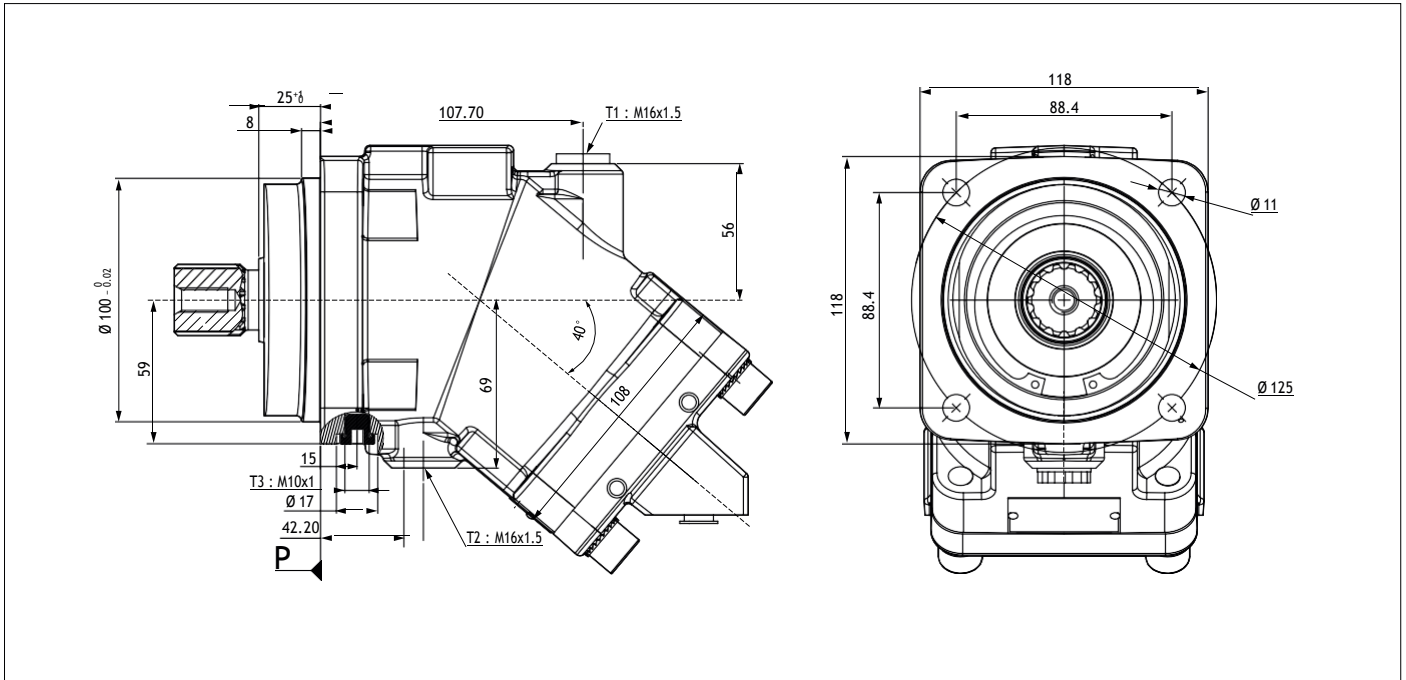

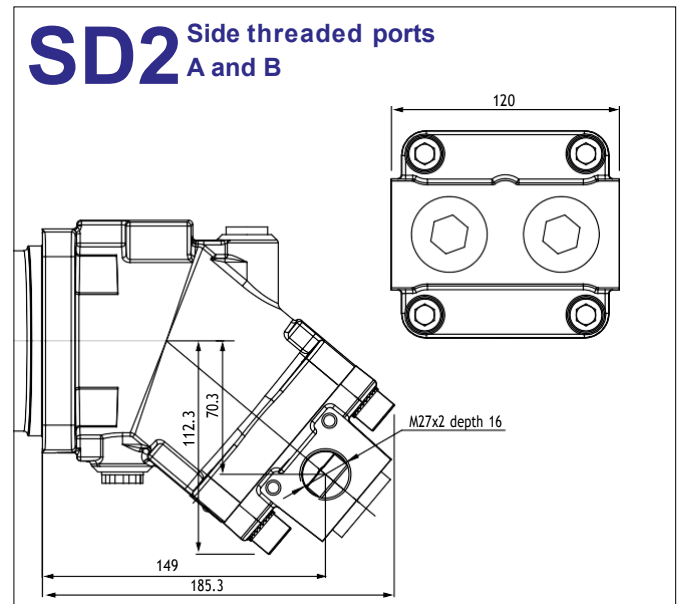
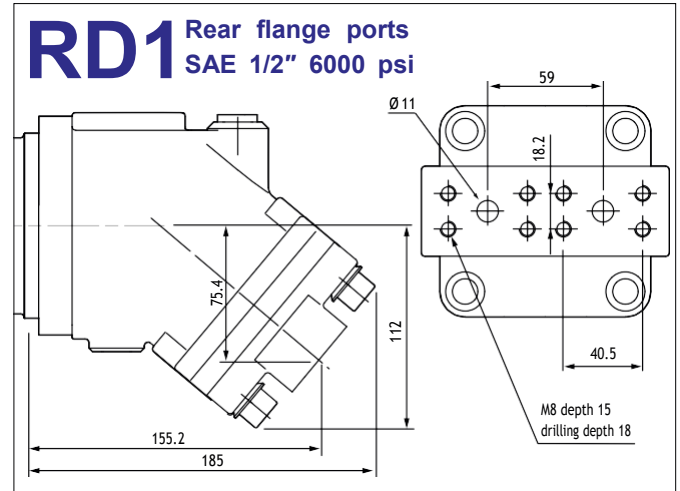
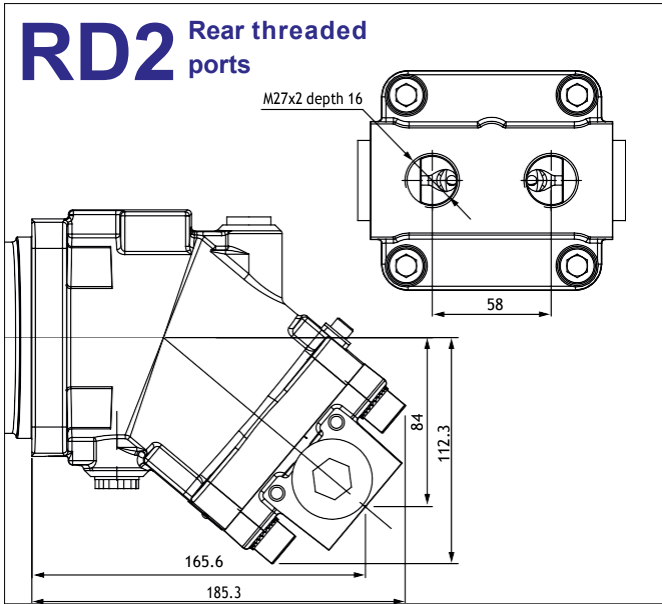

A2FO - 41 cc (ISO) Bent Axis Pump

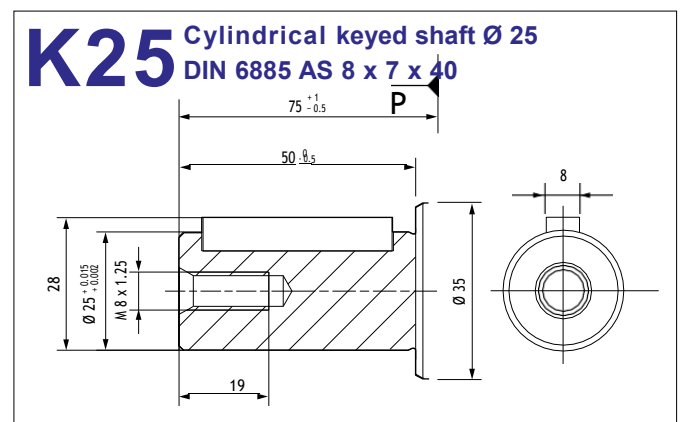
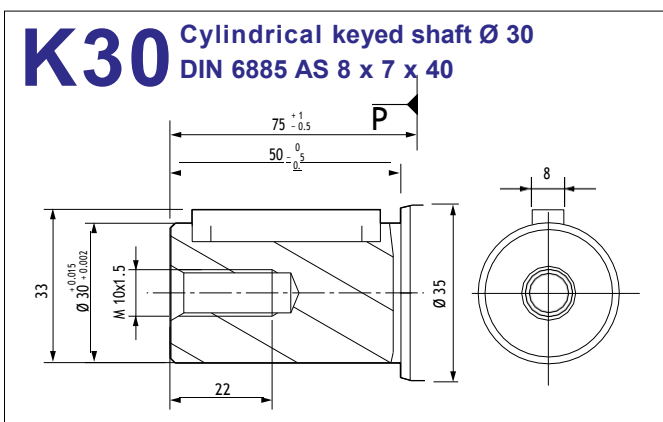
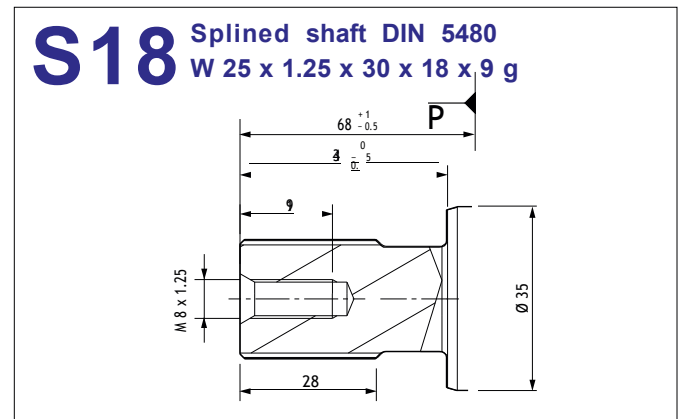
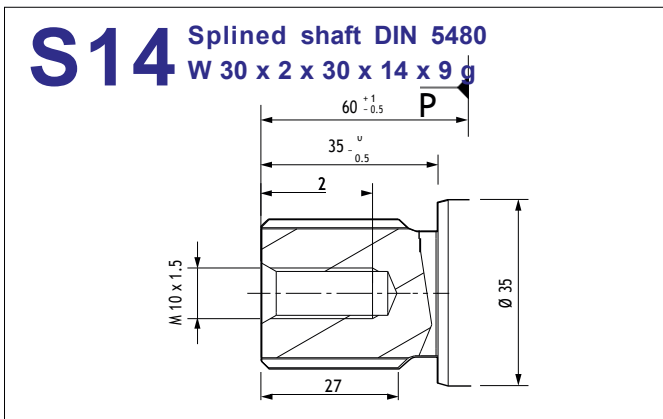
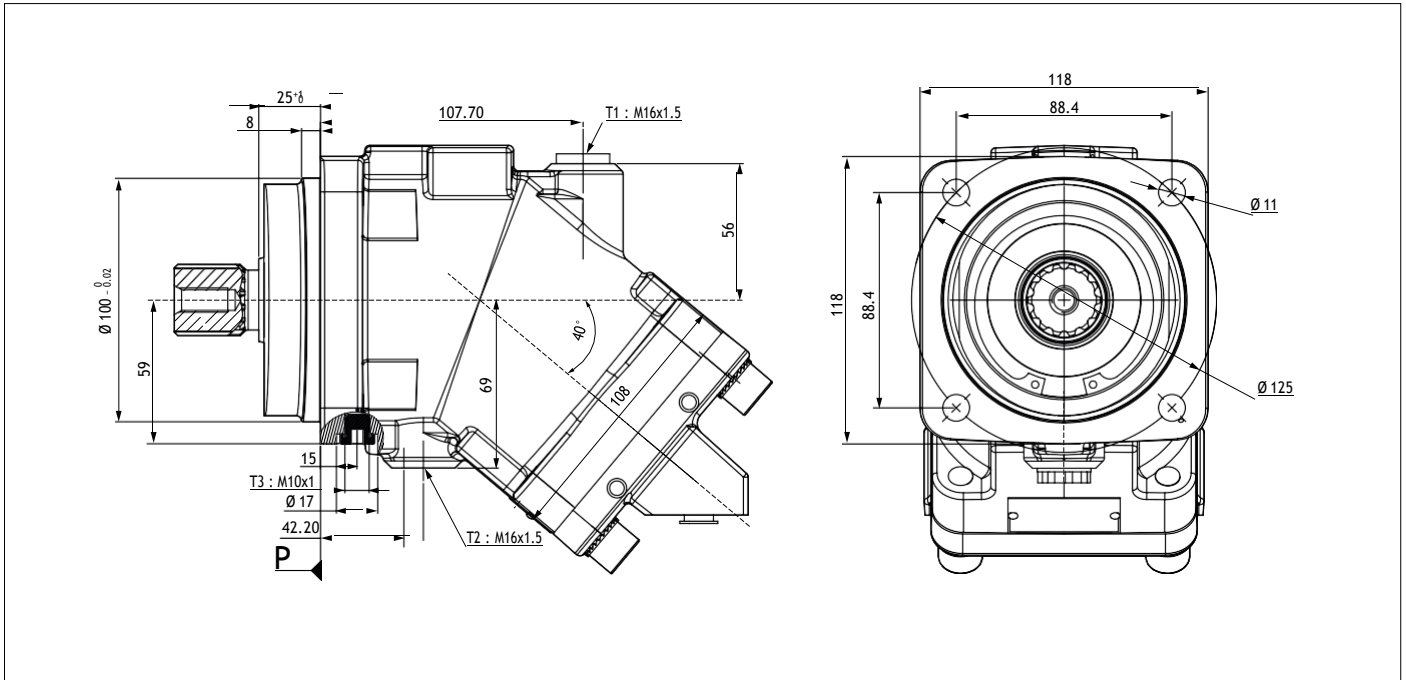

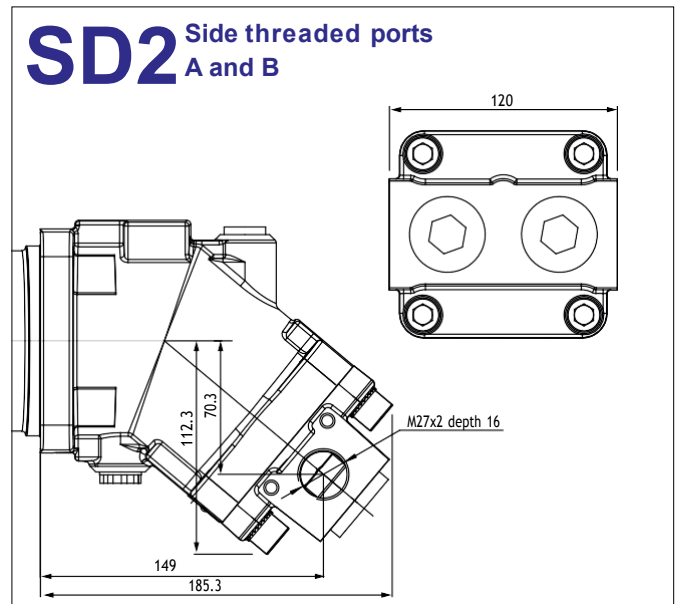
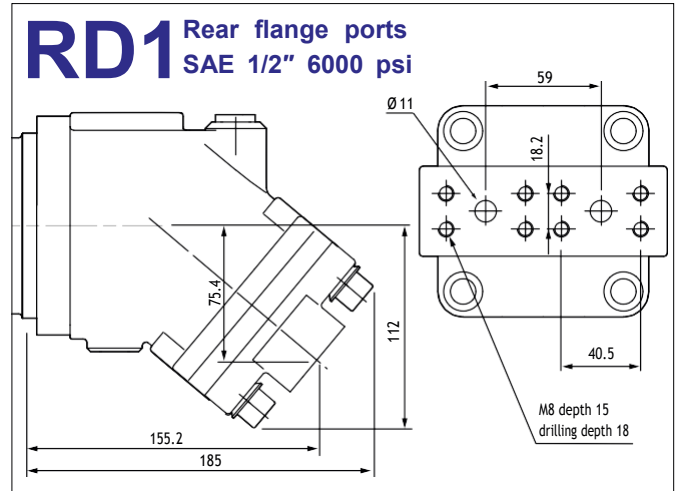
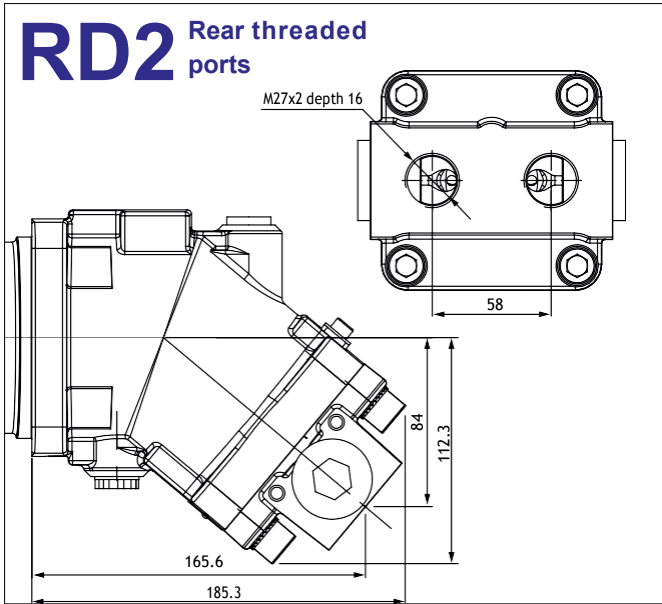

A2FO - 45 cc (ISO) Bent Axis Pump

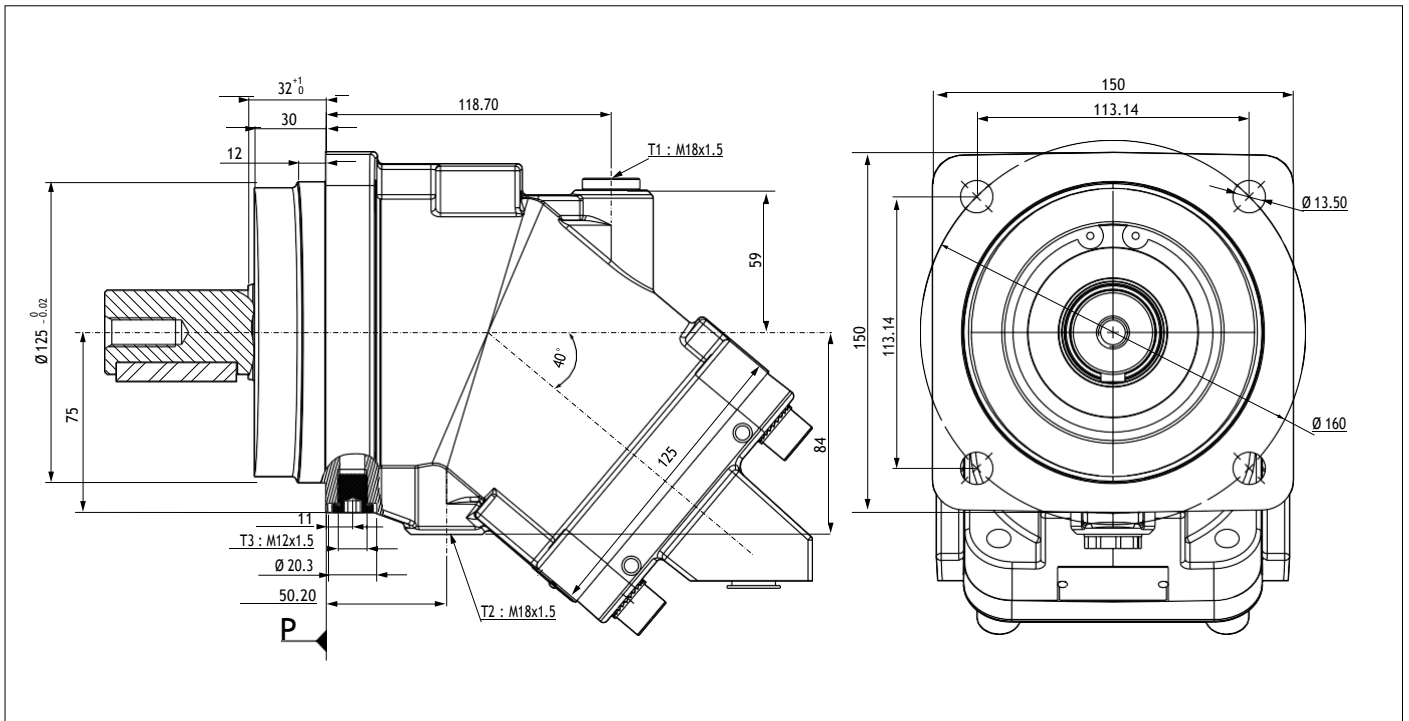

S14 Splined shaft DIN 5480 W 30 x 2 x 30 x 14 x 9 g

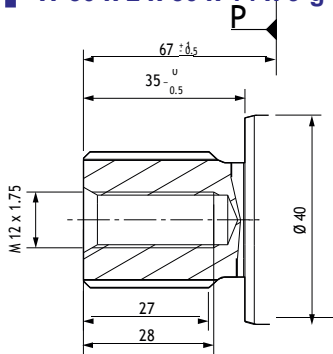

S16 Splined shaft DIN 5480 W 35 x 2 x 30 x 16 x 9 g

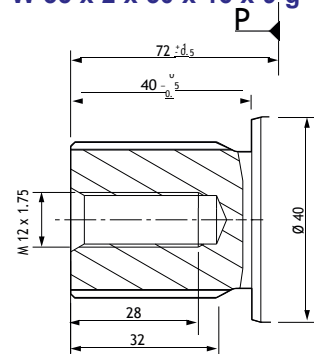

K30 Cylindrical keyed shaft Ø 30 DIN 6885 AS 8 x 7 x 40

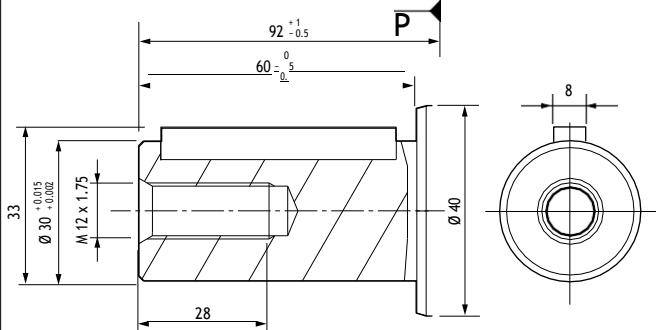

K35 Cylindrical keyed shaft Ø 35 DIN 6885 AS 10 x 8 x 50

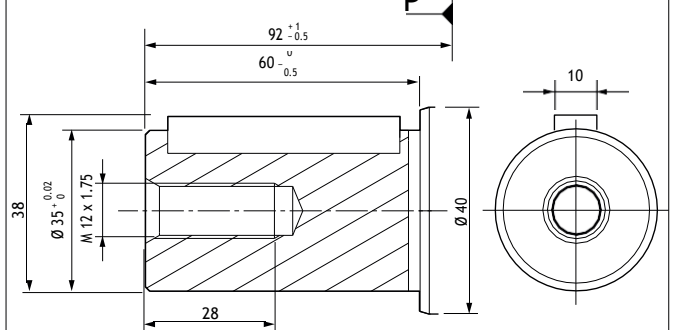

A2FO - 45 cc (ISO) Bent Axis Pump



SD2 Side threaded ports A and B

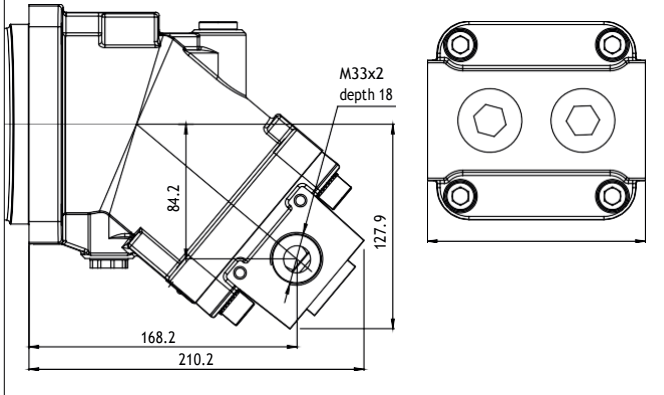

RD1 SAE flange ports, rear SAE 3/4" 6000 psi

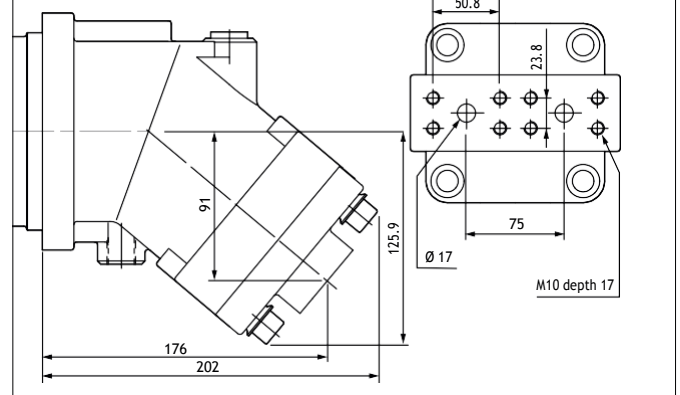

RD2 Rear threaded ports

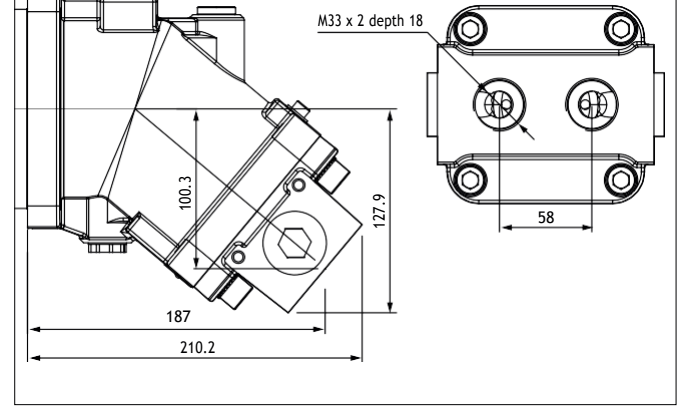

A2FO - 50 cc (ISO) Bent Axis Pump

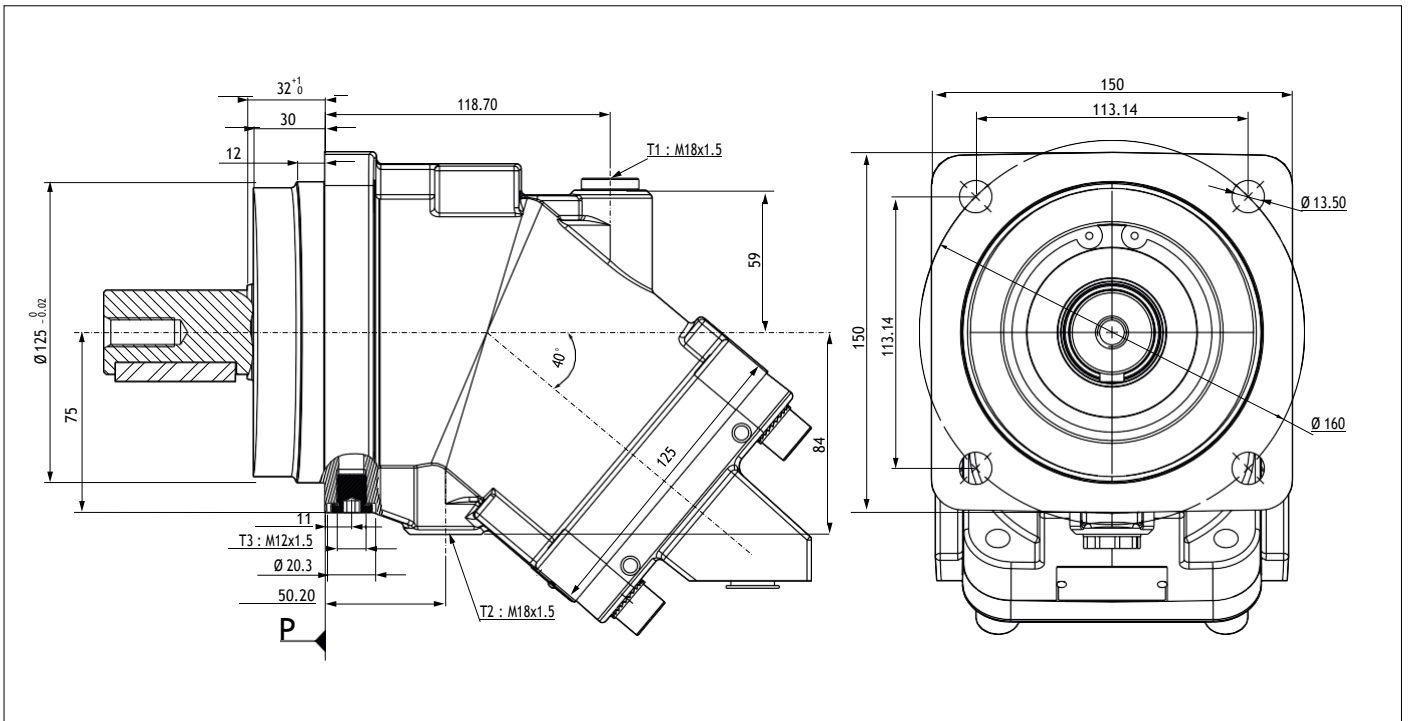

S14 Splined shaft DIN 5480 W 30 x 2 x 30 x 14 x 9 g

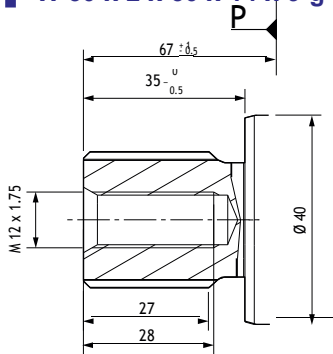

S16 Splined shaft DIN 5480 W 35 x 2 x 30 x 16 x 9 g

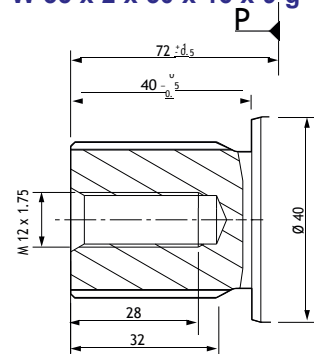

K30 Cylindrical keyed shaft $\varnothing 30$ DIN 6885 AS 8 x 7 x 40

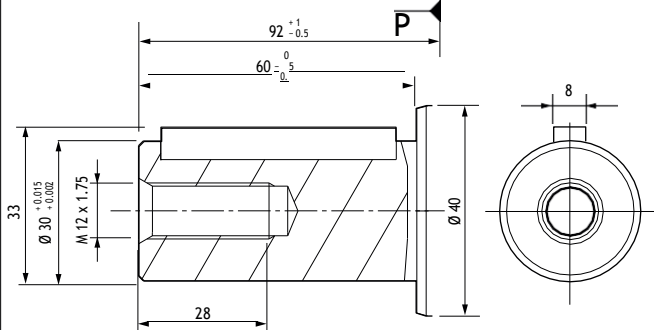

K35 Cylindrical keyed shaft $\varnothing 35$ DIN 6885 AS 10 x 8 x 50

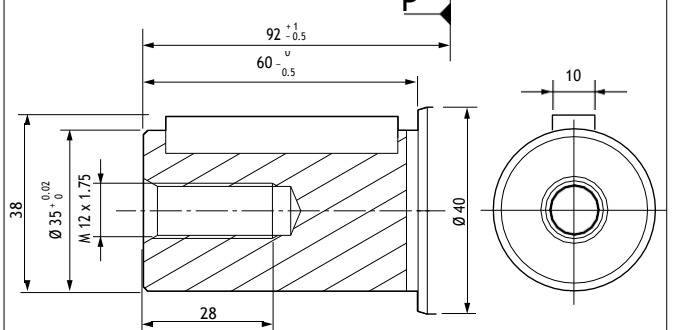

SD2 Side threaded ports A and B

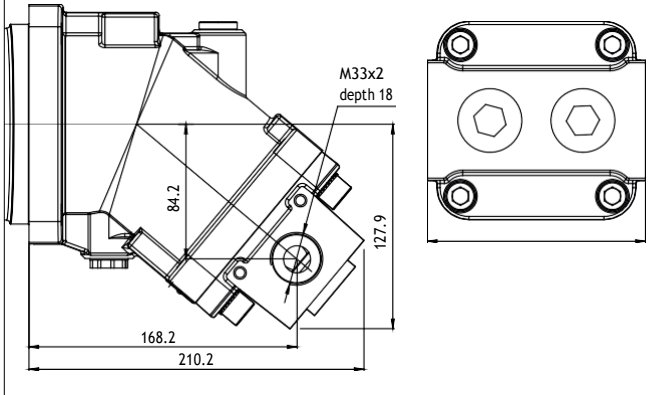

RD1 SAE flange ports, rear SAE 3/4" 6000 psi

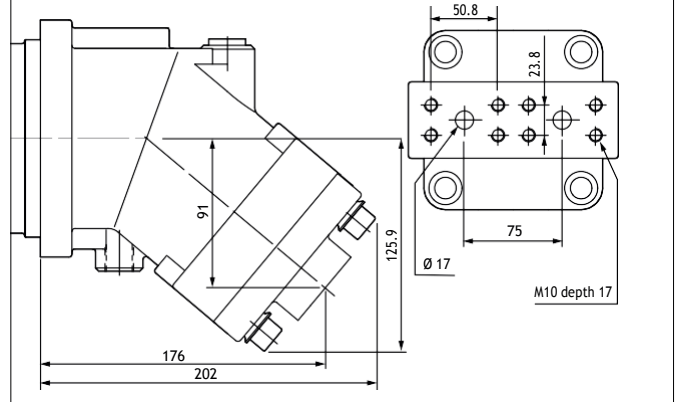

RD2 Rear threaded ports

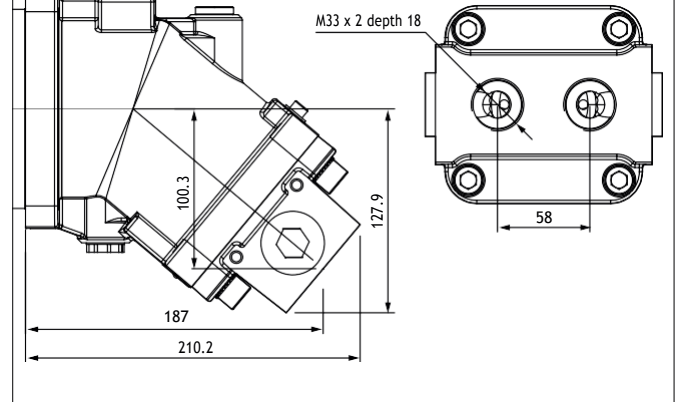

A2FO - 56 cc (ISO) Bent Axis Pump

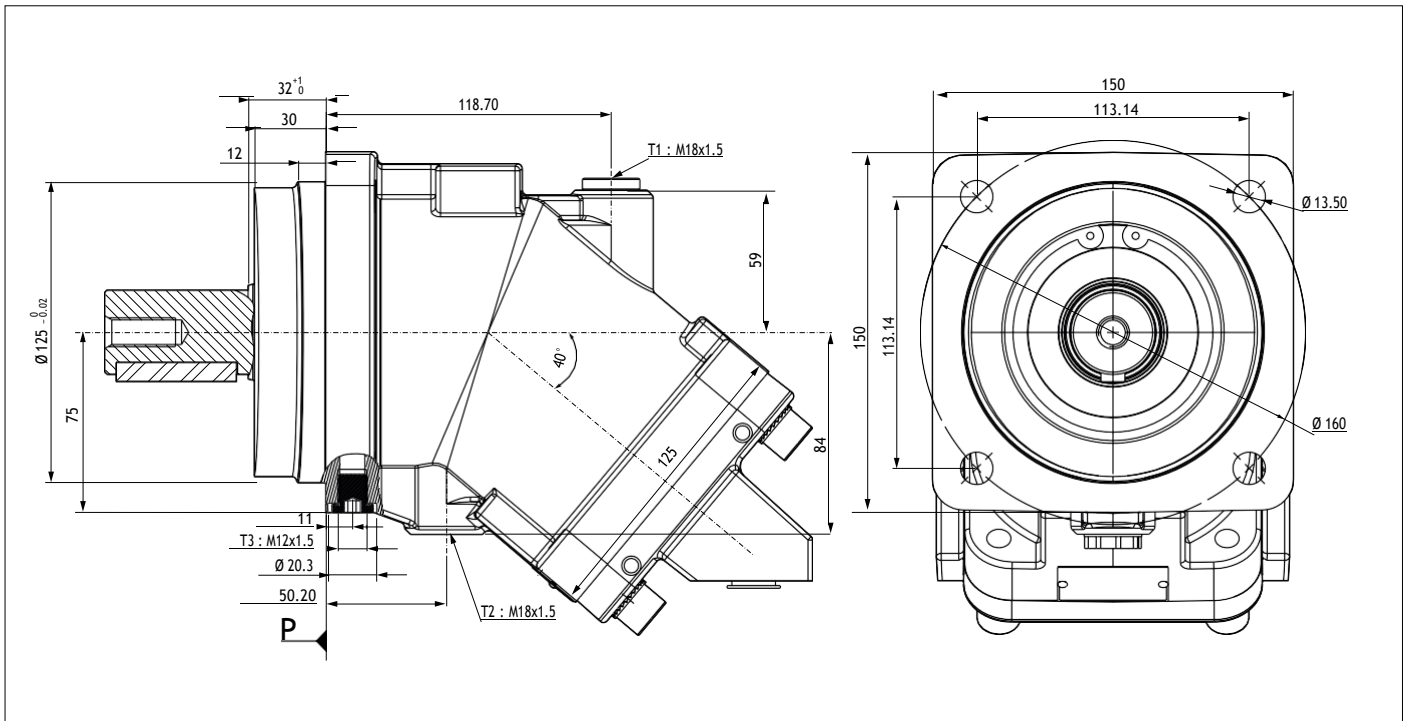

S14 Splined shaft DIN 5480 W 30 x 2 x 30 x 14 x 9 g

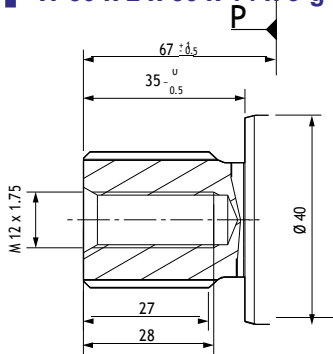

S16 Splined shaft DIN 5480 W 35 x 2 x 30 x 16 x 9 g

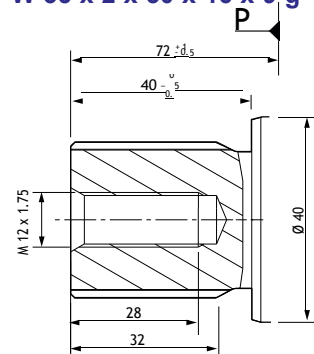

K30 Cylindrical keyed shaft Ø 30 DIN 6885 AS 8 x 7 x 40

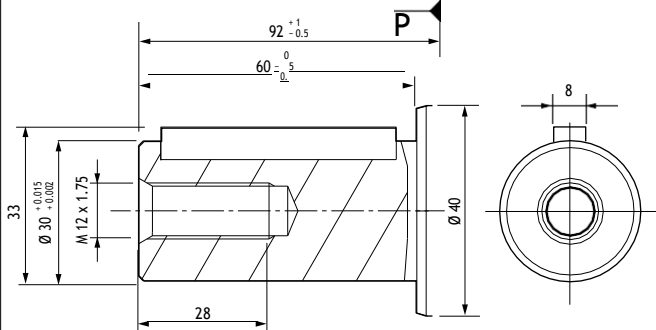

K35 Cylindrical keyed shaft Ø 35 DIN 6885 AS 10 x 8 x 50

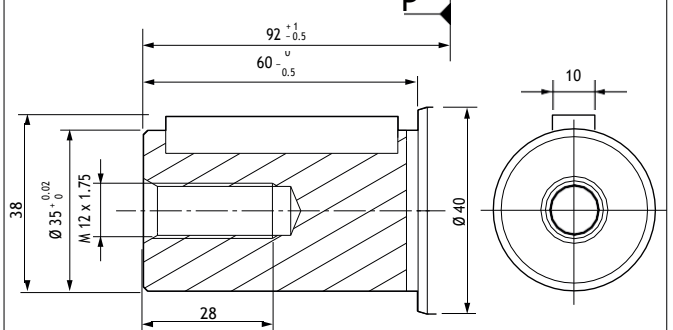

A2FO - 56 cc (ISO) Bent Axis Pump



SD2 Side threaded ports A and B

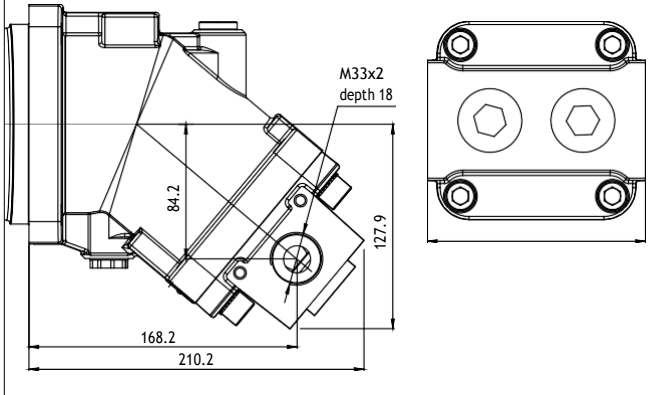

RD1 SAE flange ports, rear SAE 3/4" 6000 psi

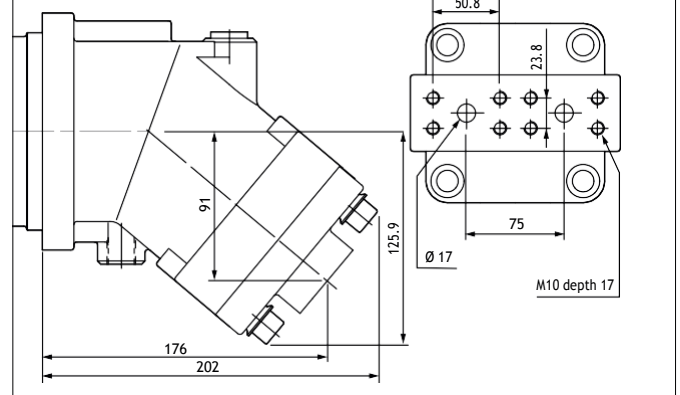

RD2 Rear threaded ports

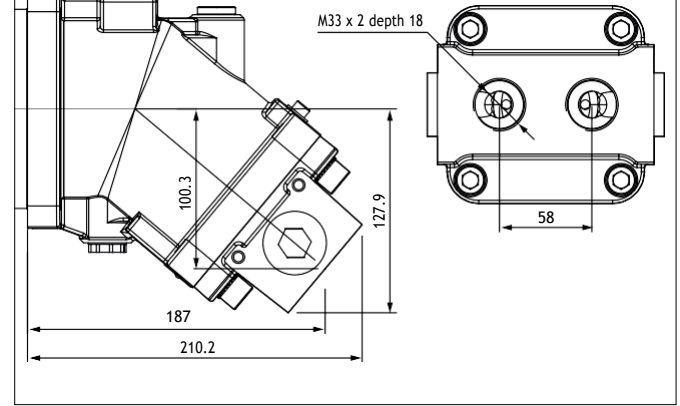

A2FO - 63 cc (ISO) Bent Axis Pump

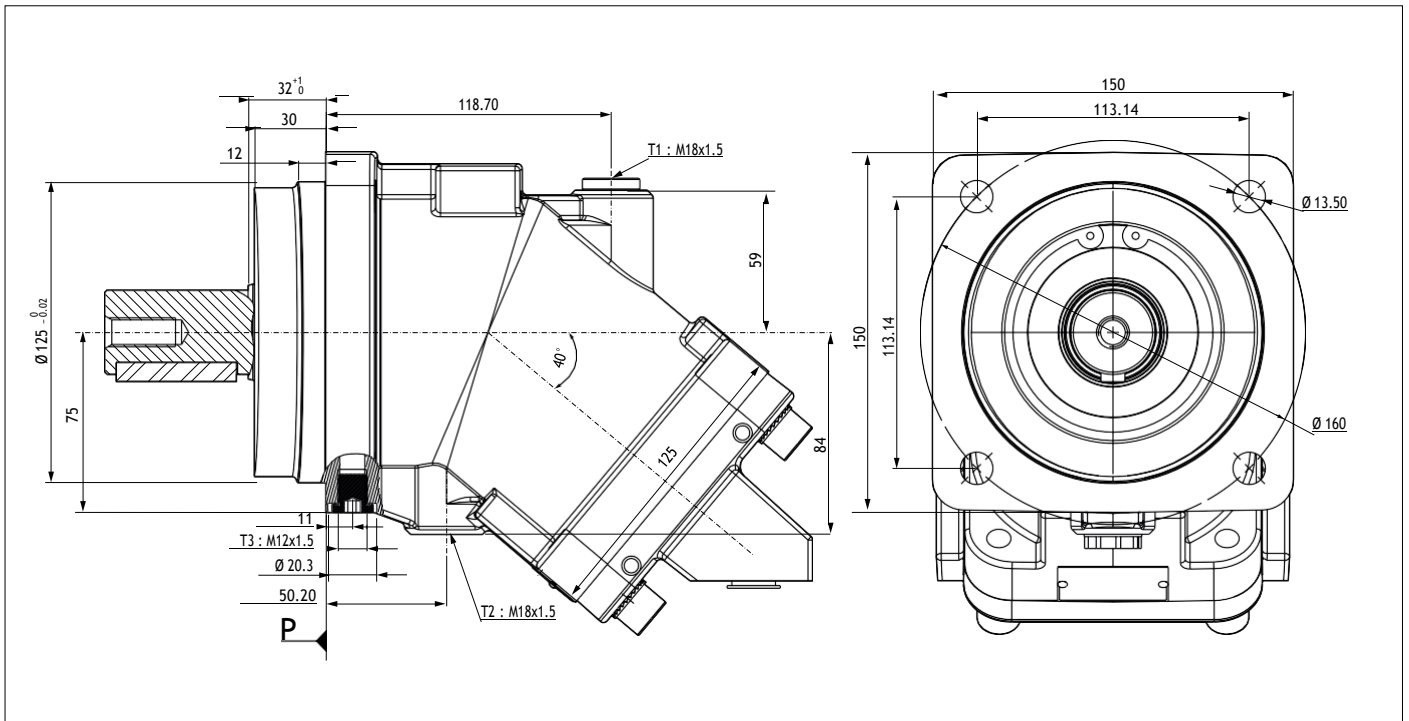

S14 Splined shaft DIN 5480 W 30 x 2 x 30 x 14 x 9 g

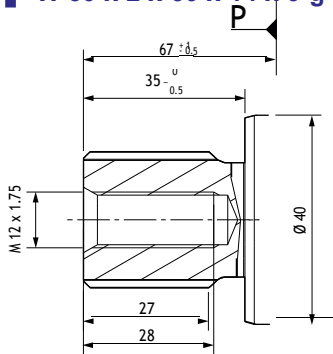

S16 Splined shaft DIN 5480 W 35 x 2 x 30 x 16 x 9 g

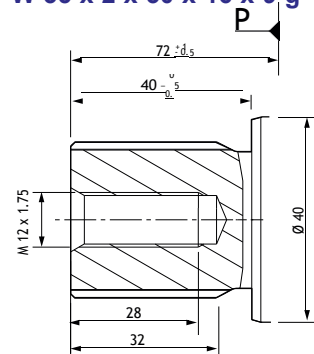

K30 Cylindrical keyed shaft $\varnothing 30$ DIN 6885 AS 8 x 7 x 40

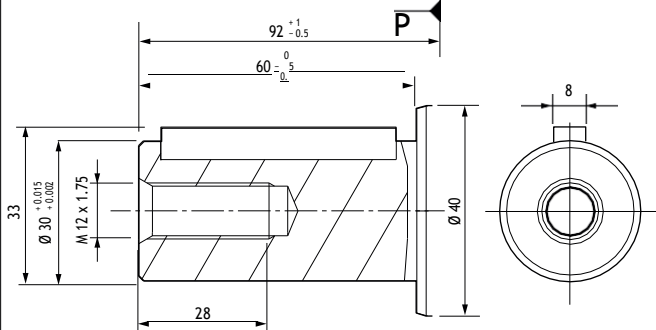

K35 Cylindrical keyed shaft $\varnothing 35$ DIN 6885 AS 10 x 8 x 50

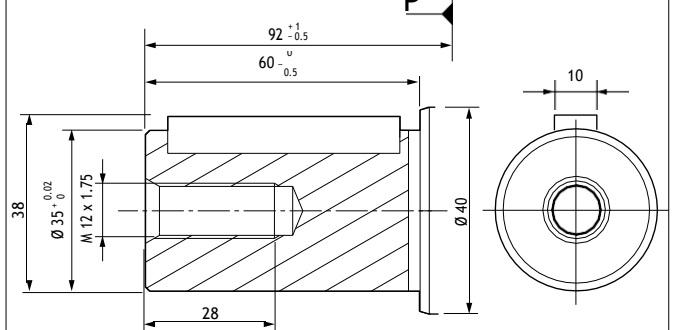

SD2 Side threaded ports A and B

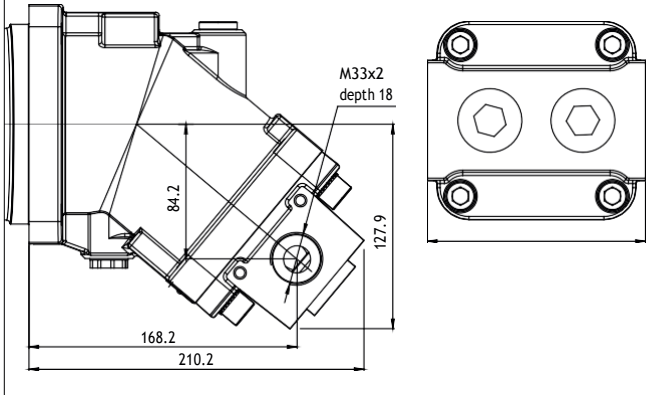

RD1 SAE flange ports, rear SAE 3/4" 6000 psi

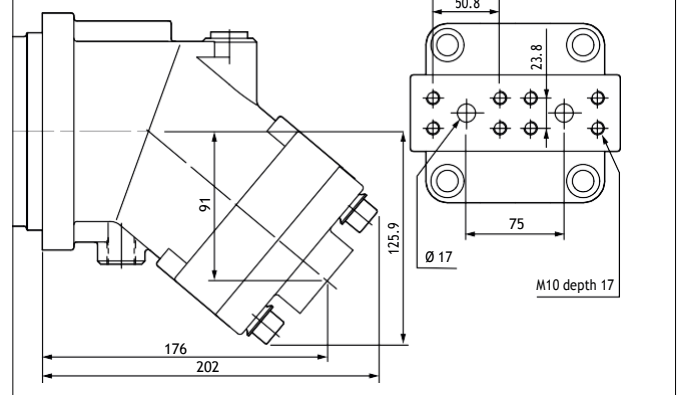

RD2 Rear threaded ports

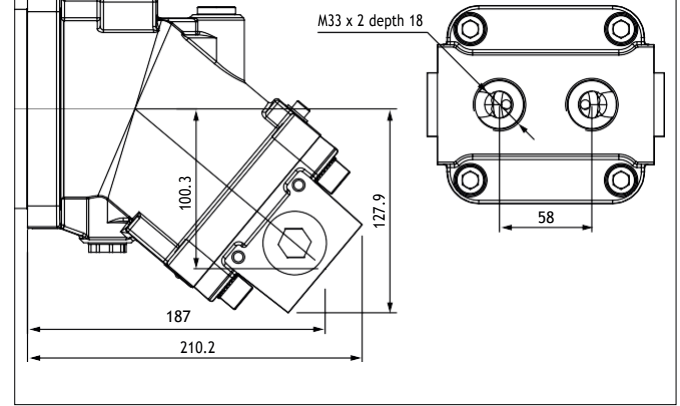

A2FO - 80 cc (ISO) Bent Axis Pump

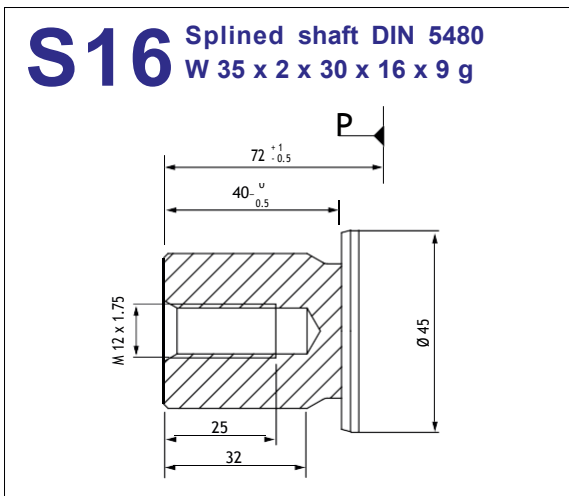
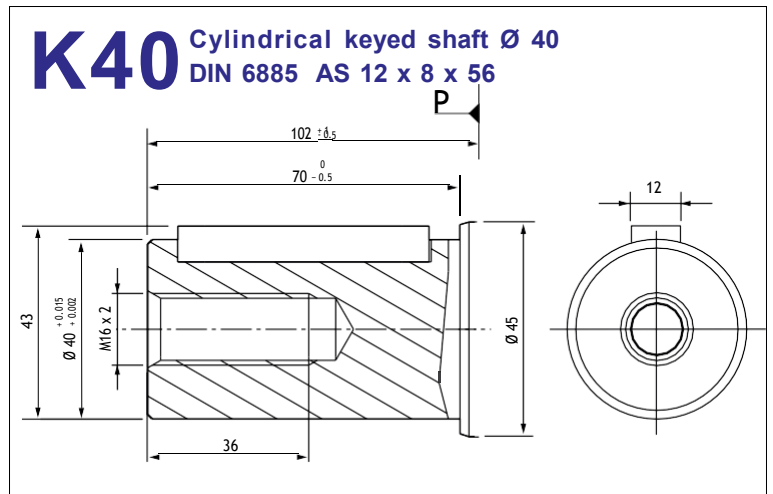
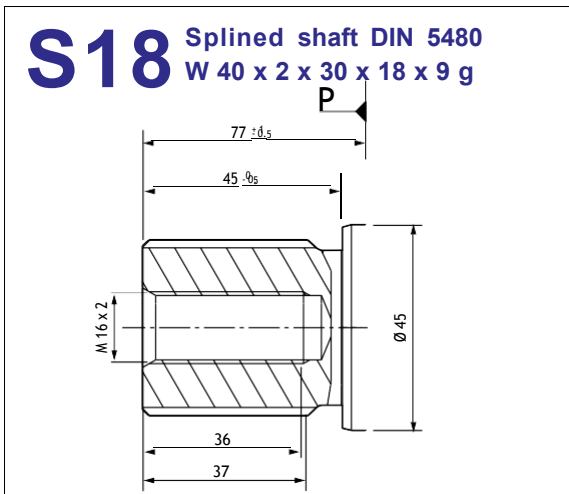
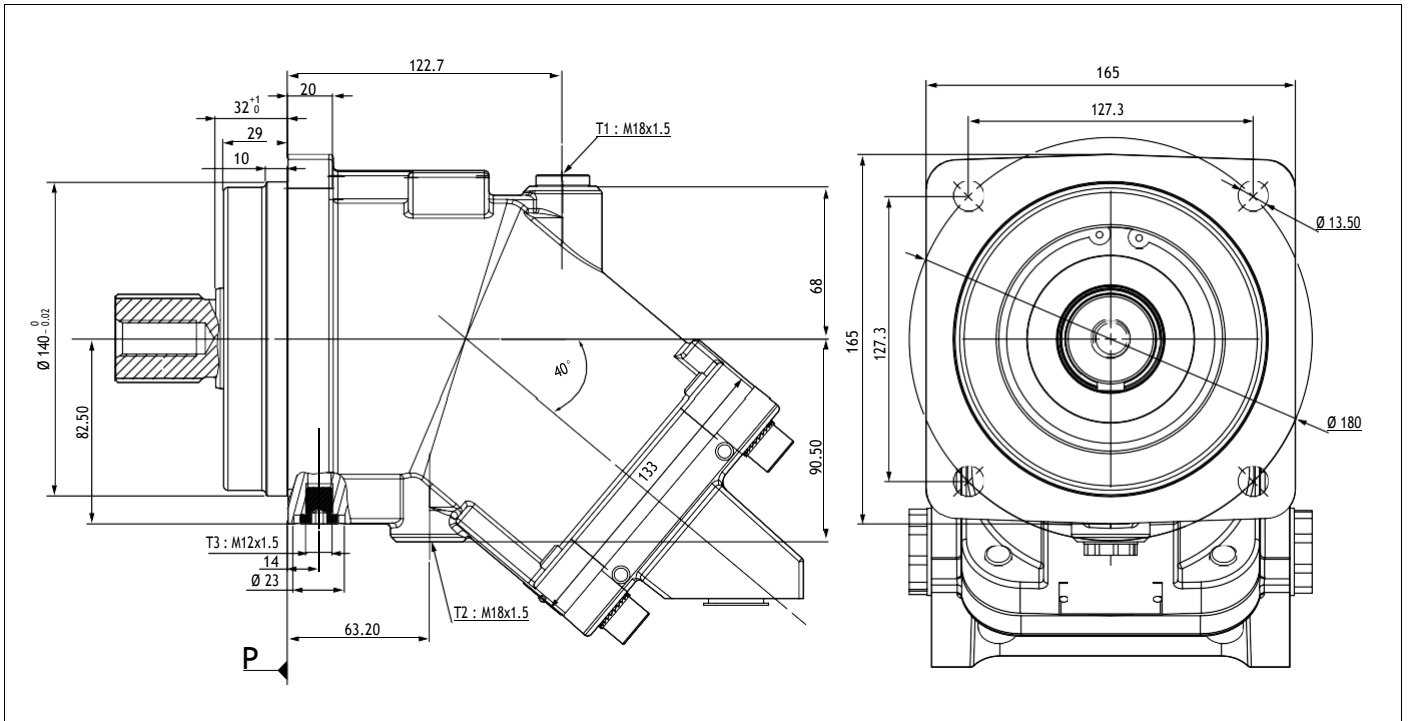

A2FO - 80 cc (ISO) Bent Axis Pump

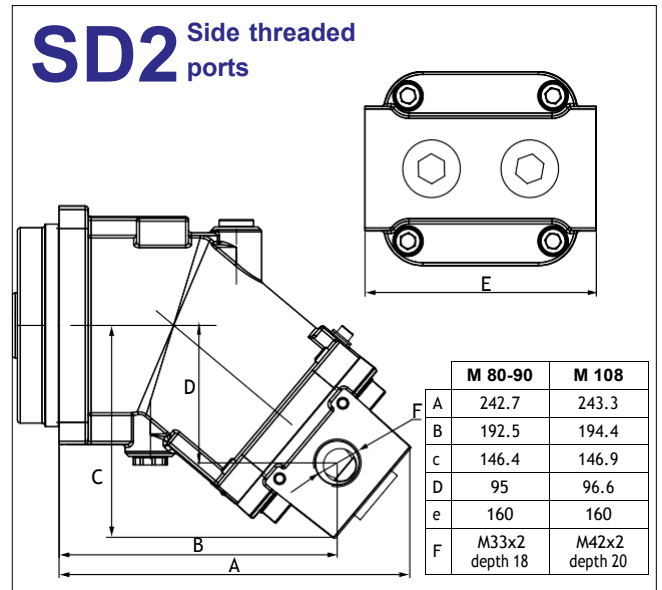
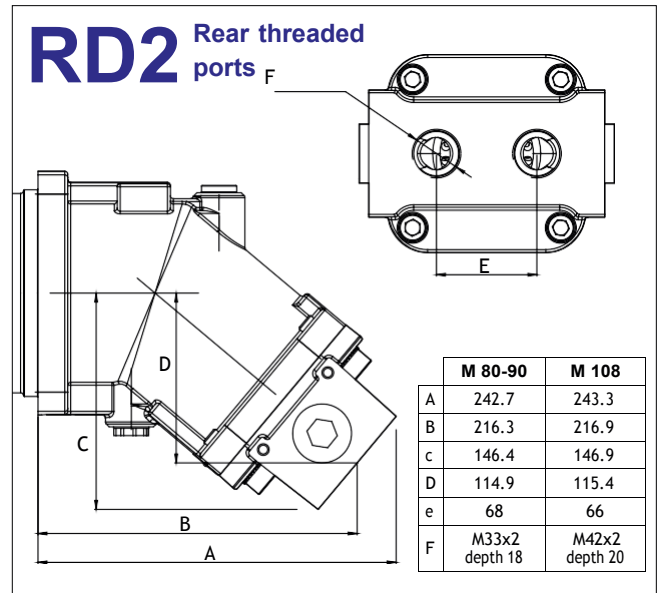
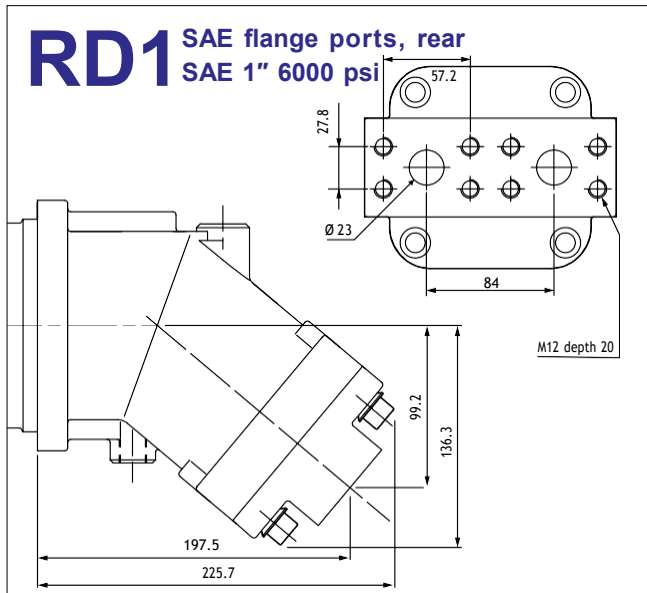

A2FO - 90 cc (ISO) Bent Axis Pump

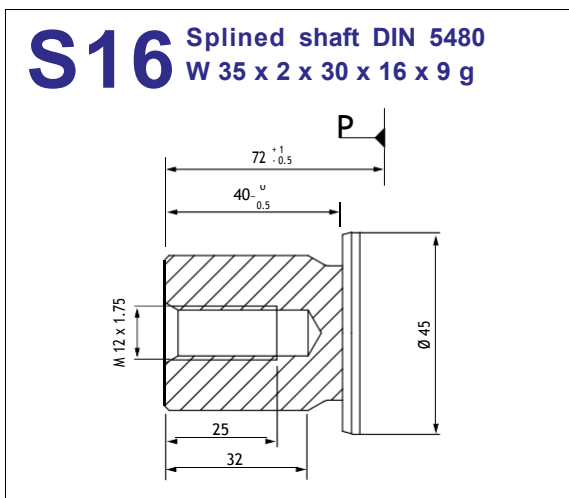
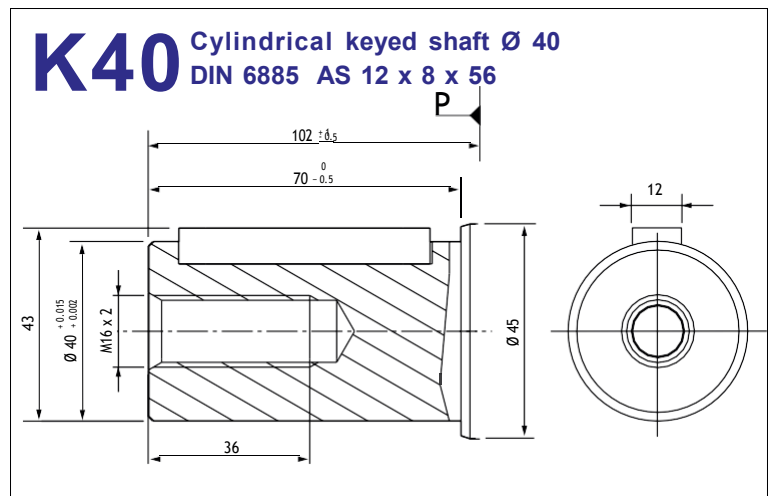
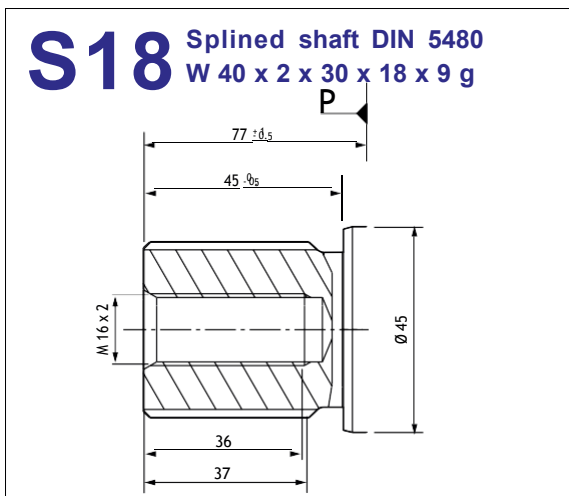
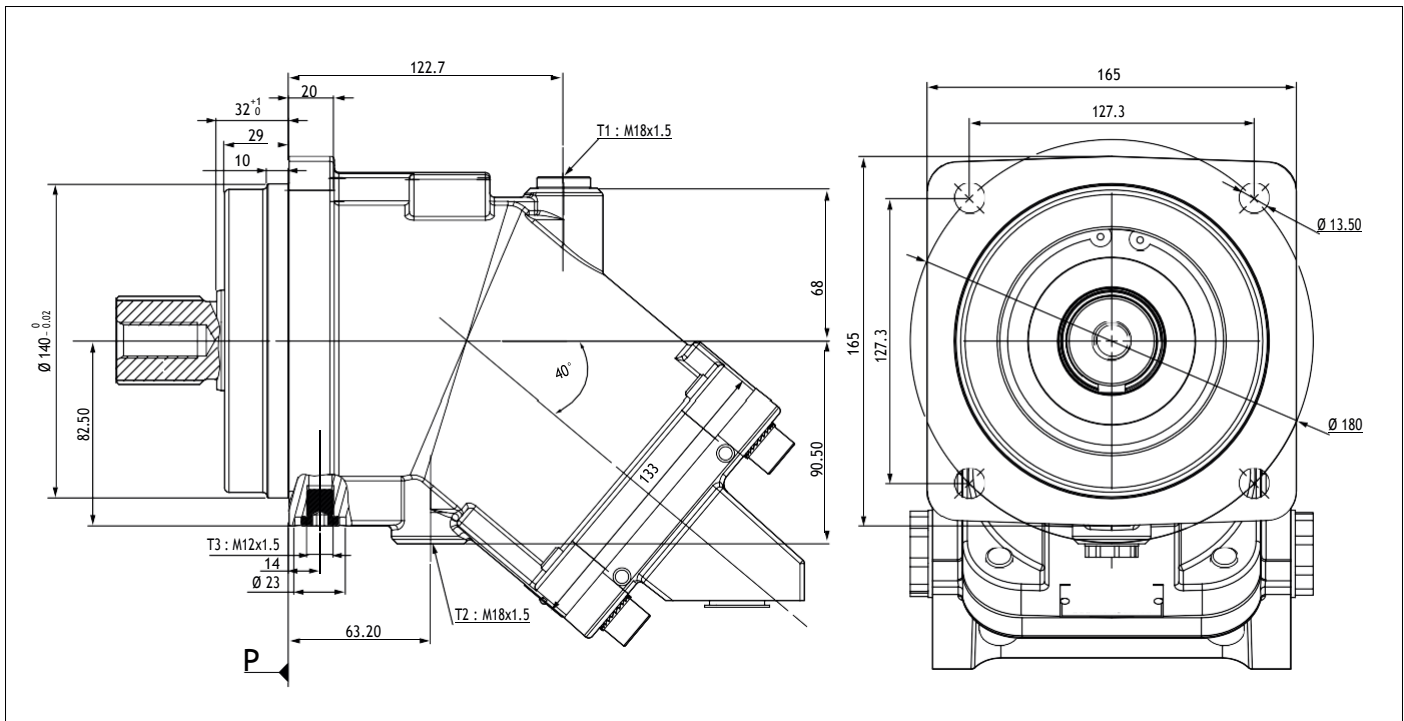

A2FO - 90 cc (ISO) Bent Axis Pump

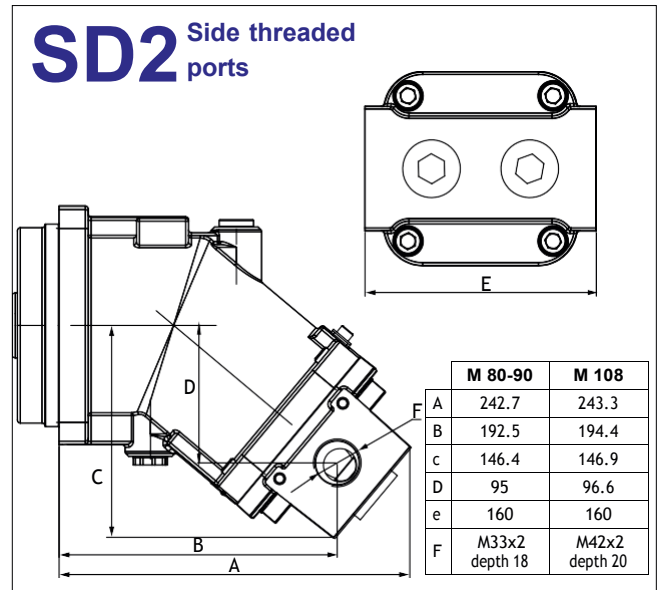
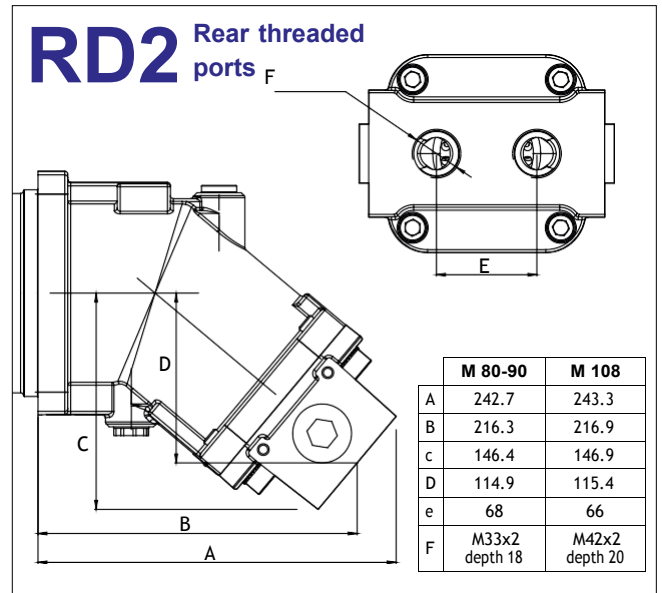
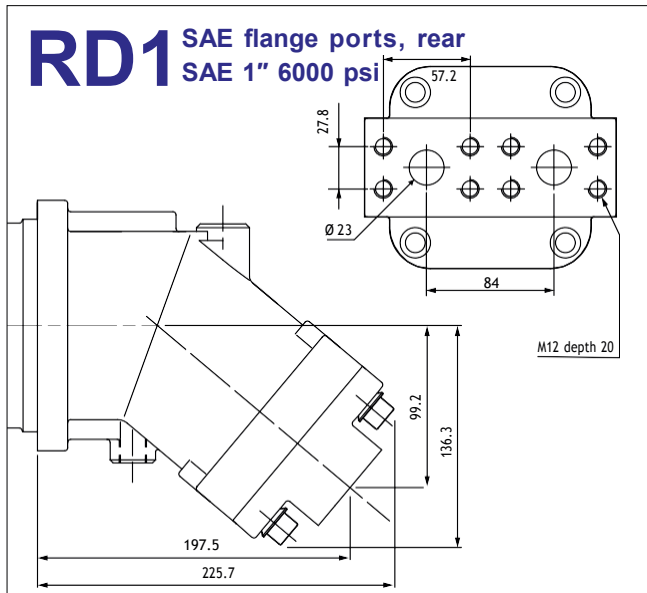

A2FO - 108 cc (ISO) Bent Axis Pump

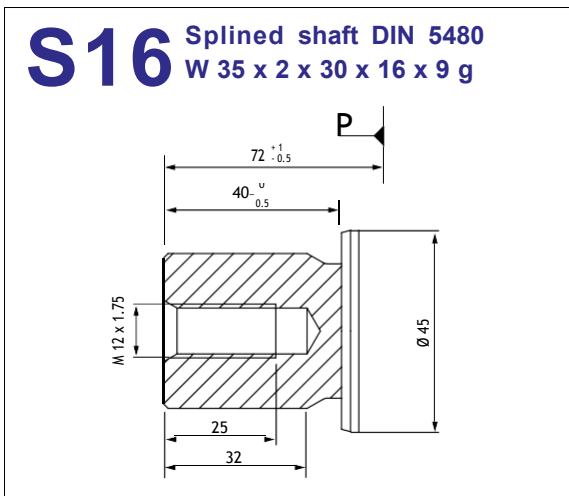
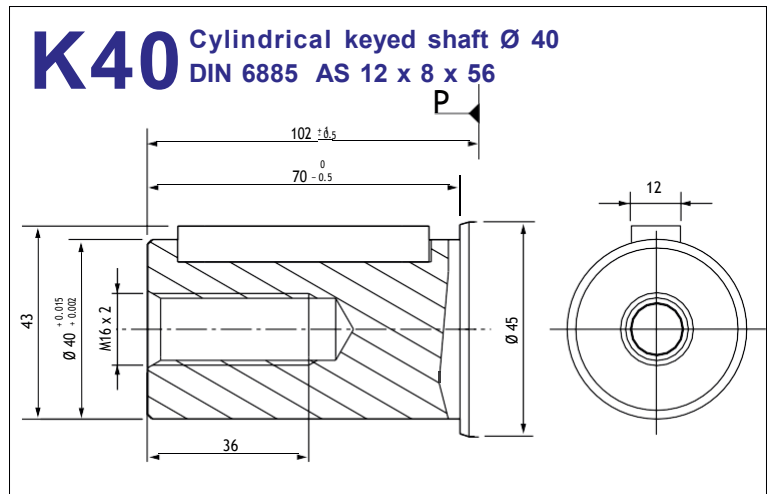
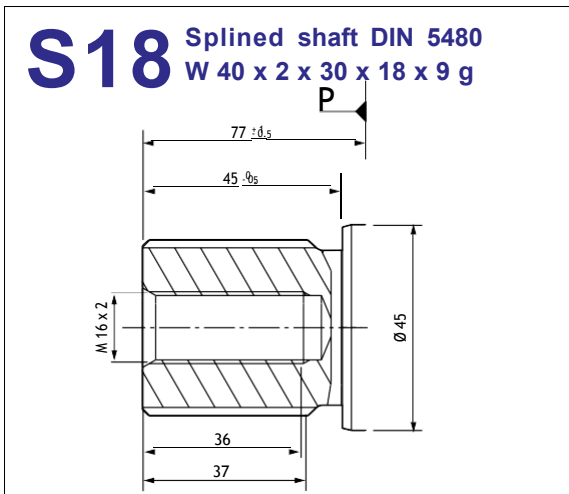
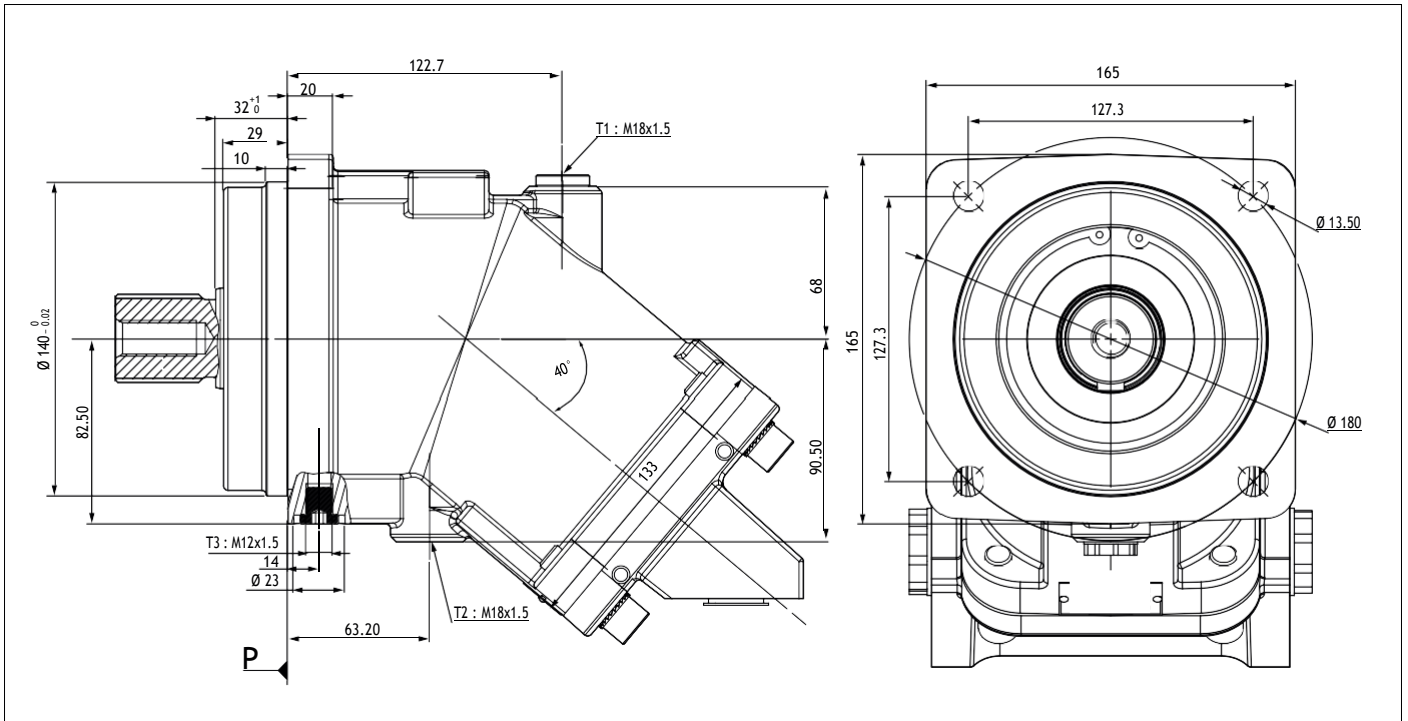

A2FO - 108 cc (ISO) Bent Axis Pump

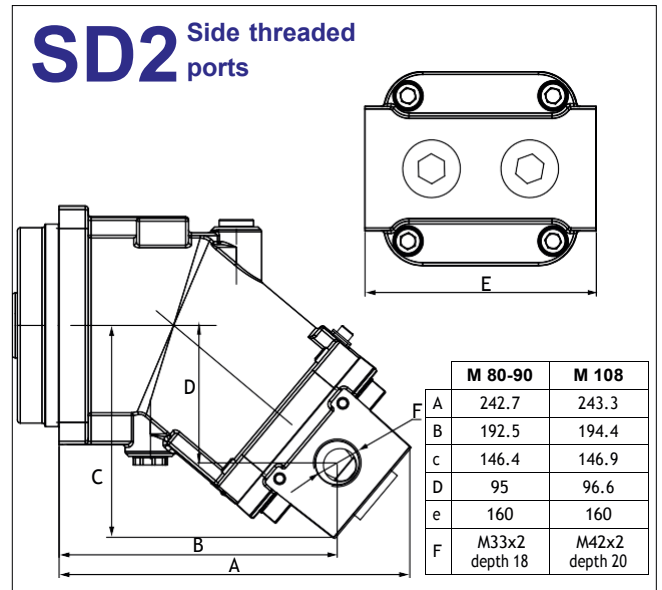
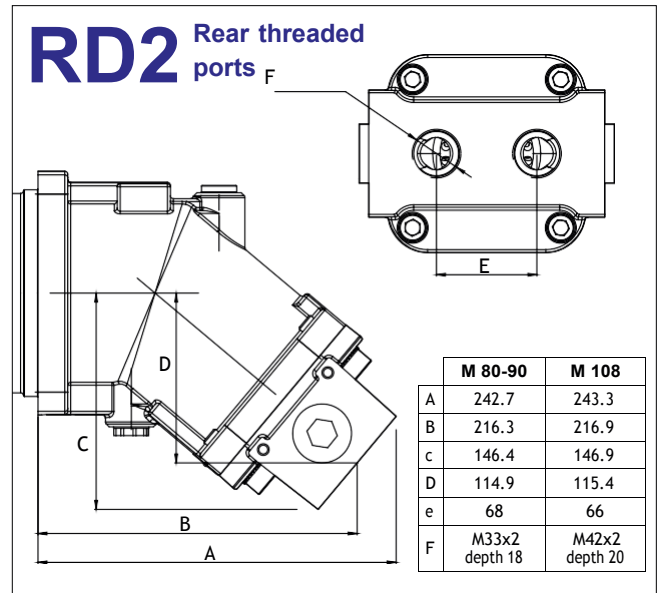
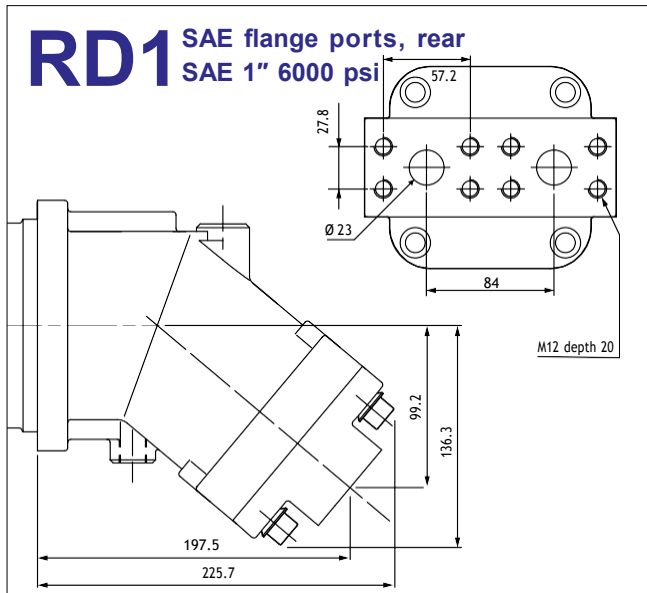

A2FO - 125 cc (ISO) Bent Axis Pump

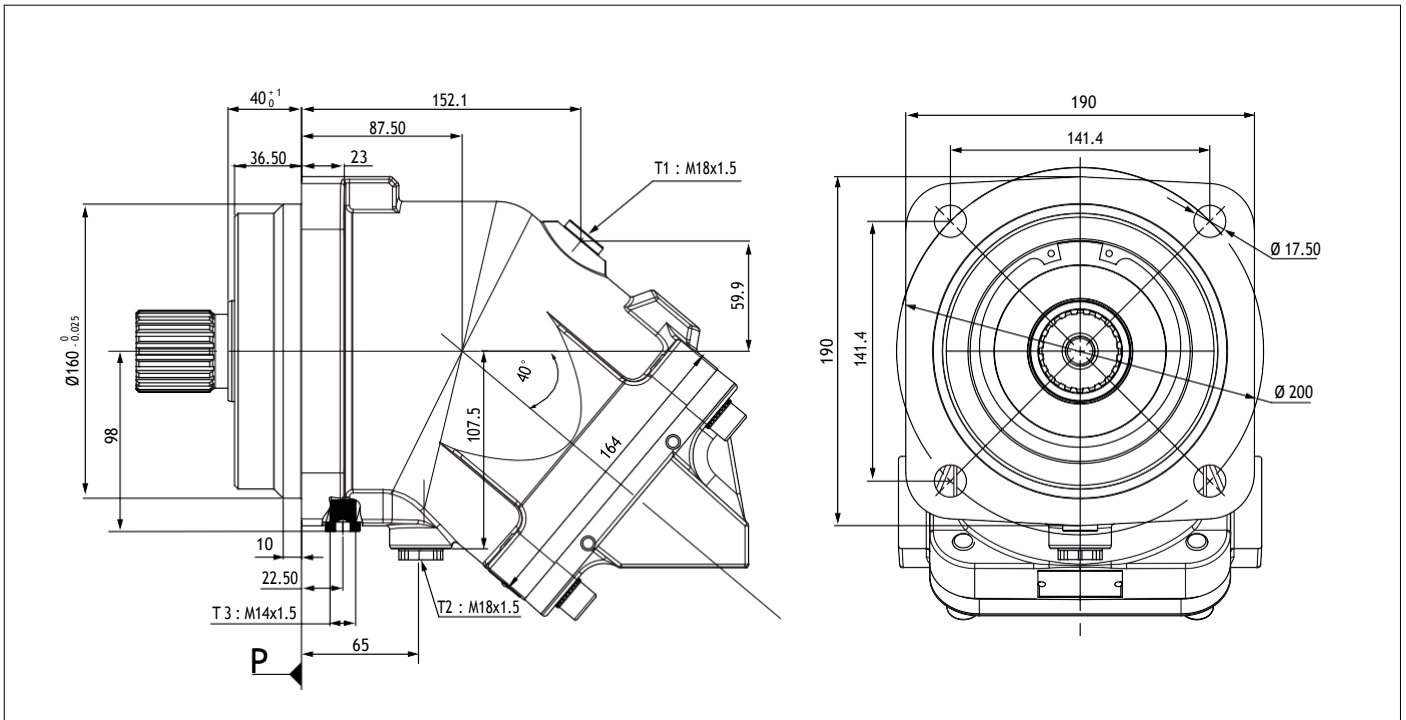

S21 Splined shaft DIN 5480 W 45 x 2 x 30 x 21 x 9 g

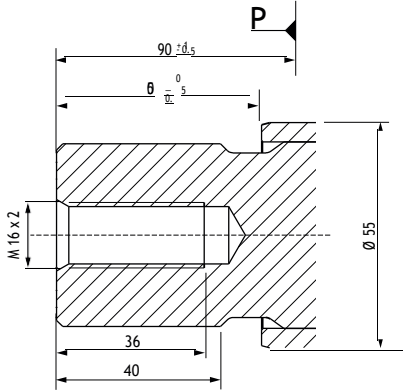

K45 Cylindrical keyed shaft Ø 45 DIN 6885 AS 14 x 9 x 63

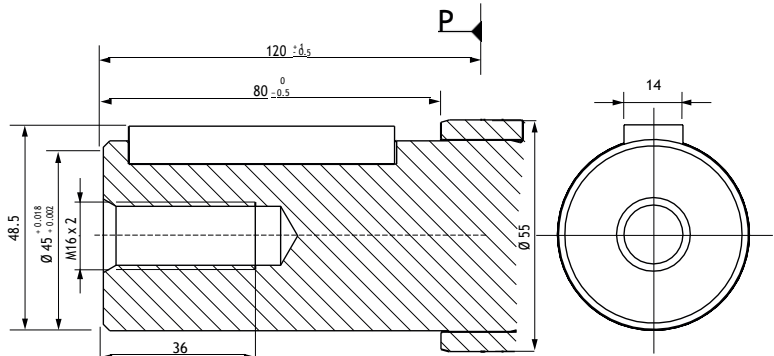

S18 Splined shaft DIN 5480 W 40 x 2 x 30 x 18 x 9 g

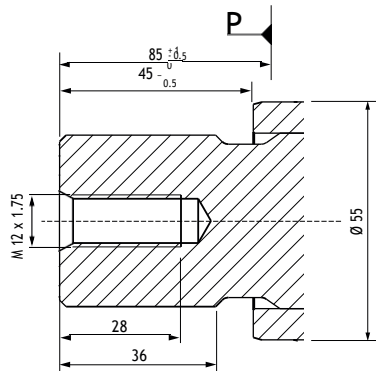

K40 Cylindrical keyed shaft Ø 40 DIN 6885 AS 12 x 8 x 56

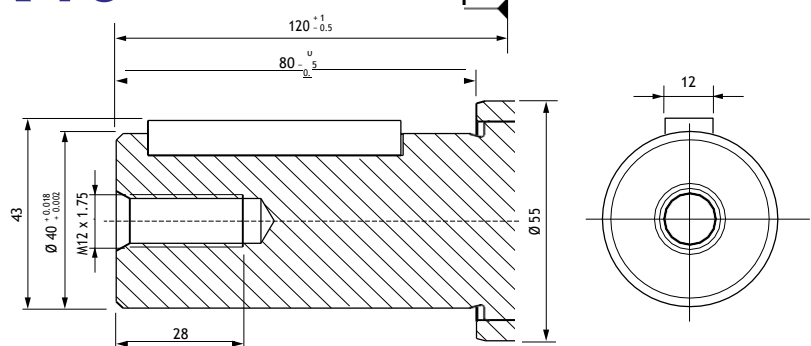

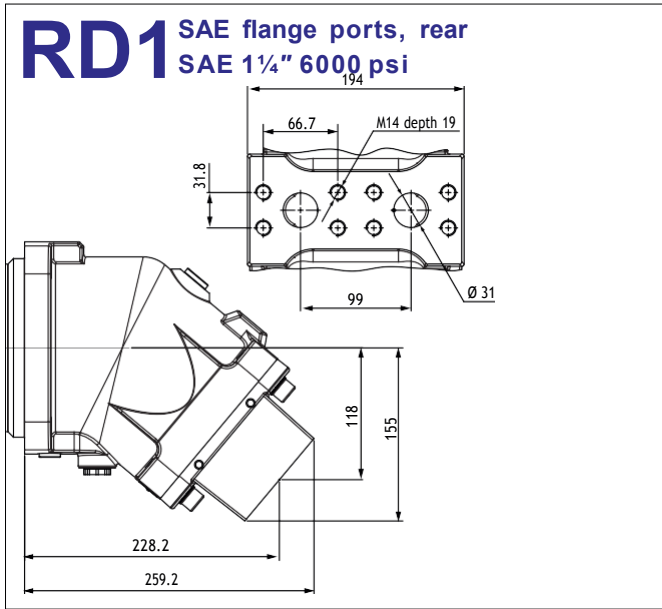

A2FO - 160 cc (ISO) Bent Axis Pump

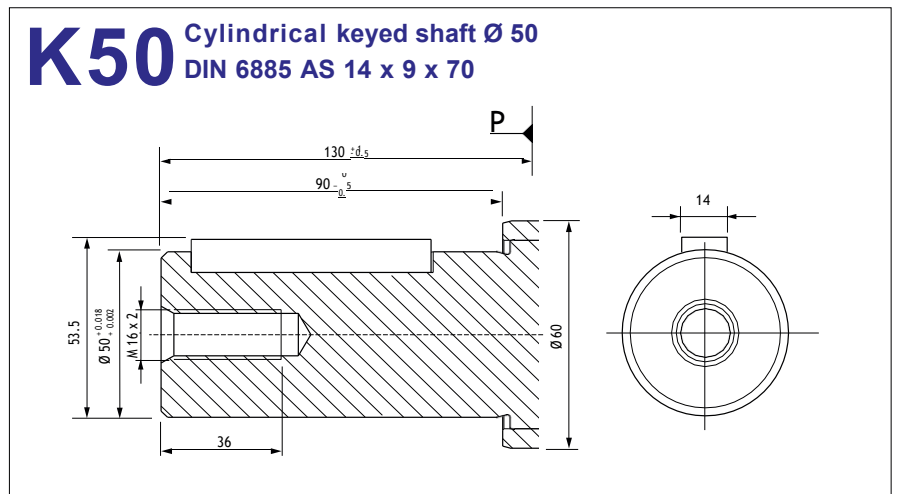
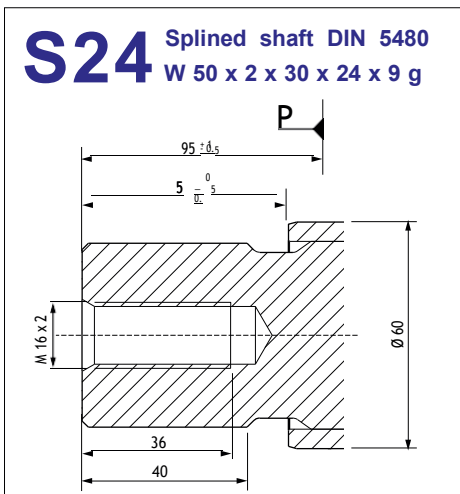
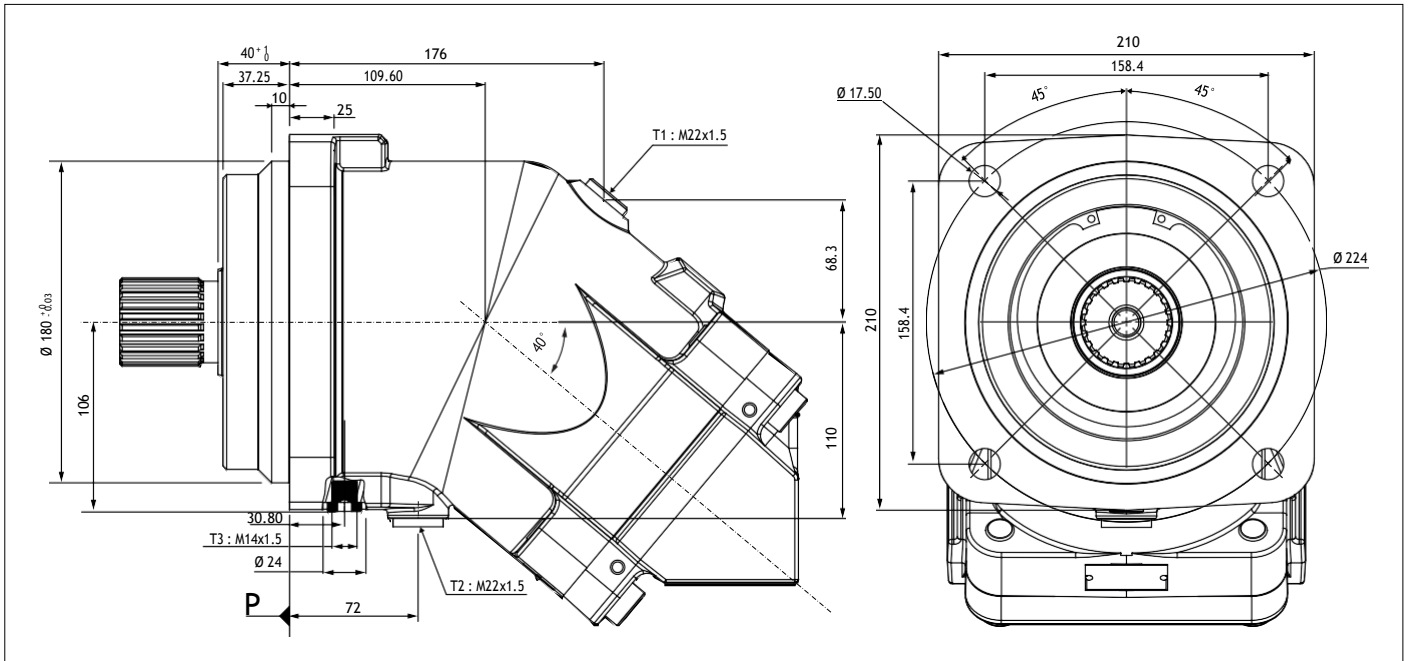

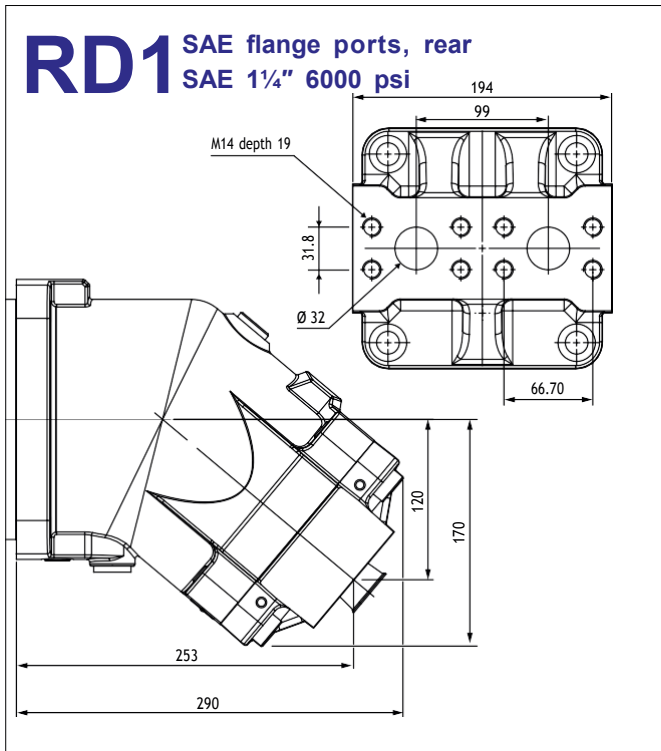

A2FO - 180 cc (ISO) Bent Axis Pump

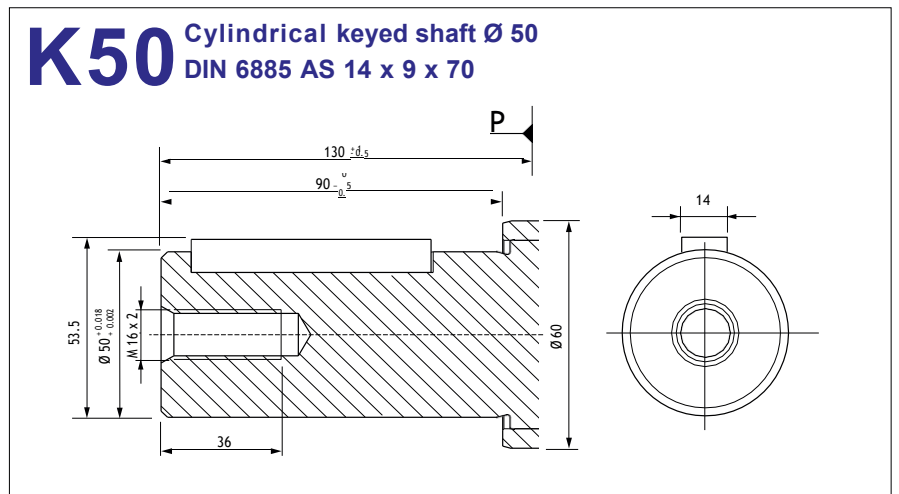
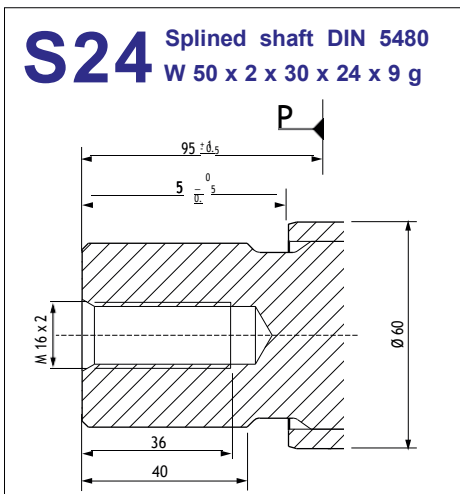
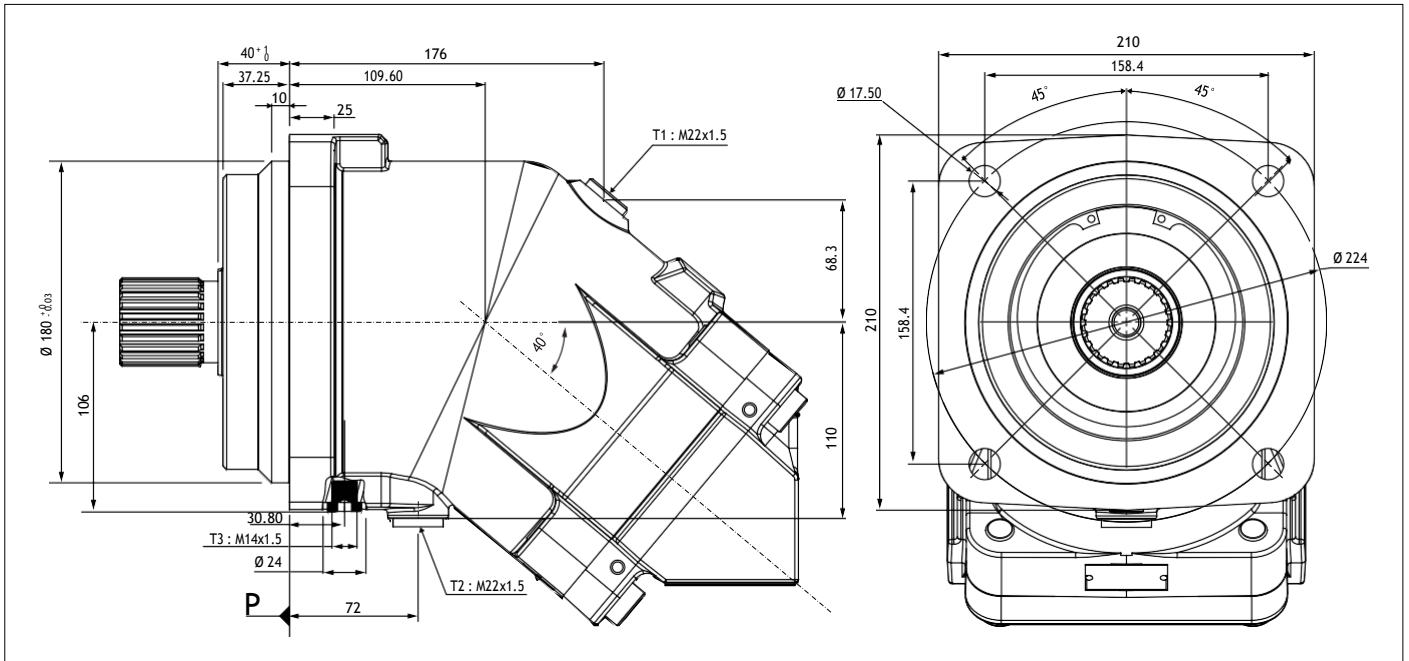

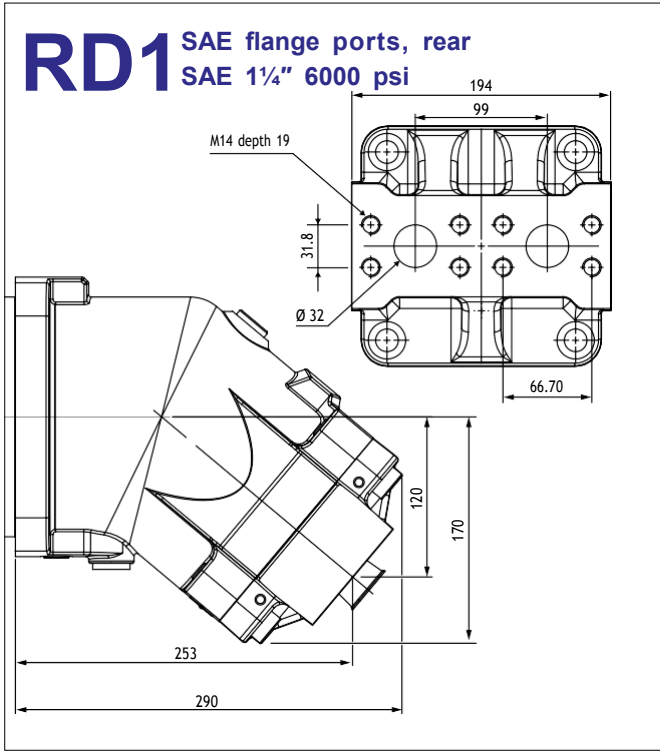

Special Shaft Drive Options for A2FO Pumps

For the Special applications, we produce Special Shaft Drive for the A2FO Pumps.
Details are listed in below.

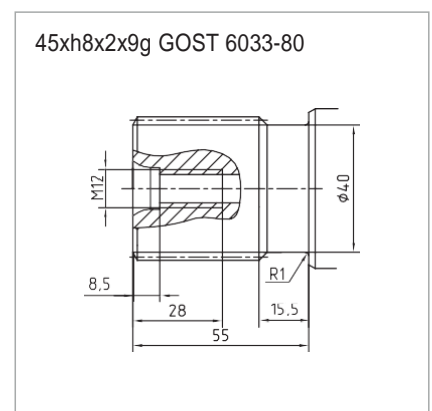
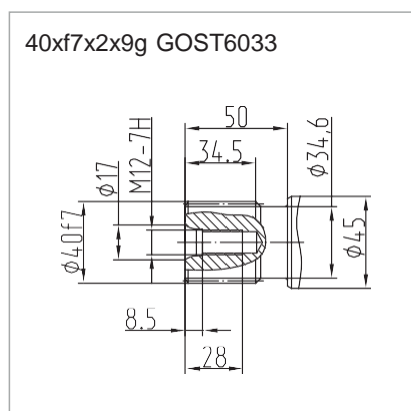
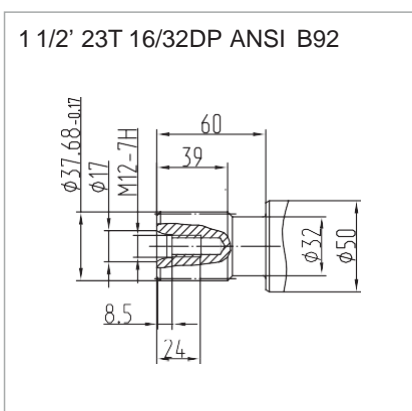
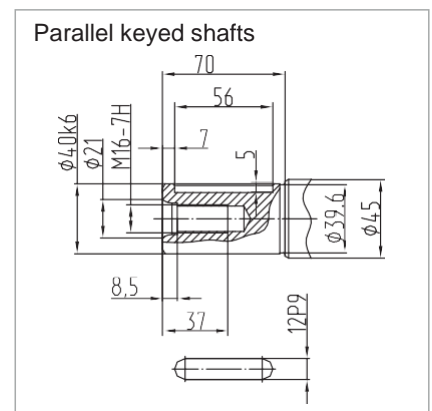
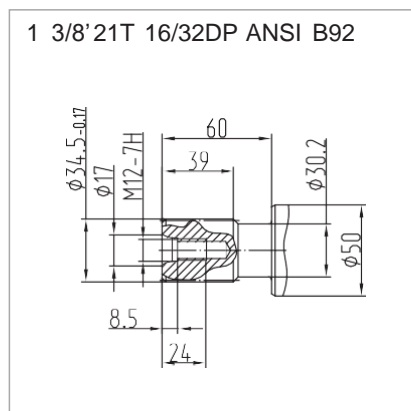
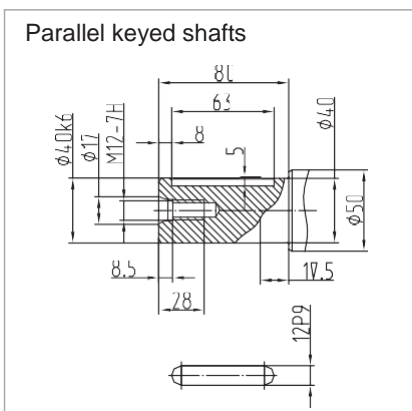
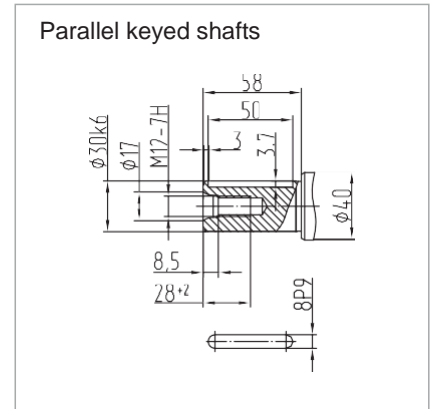
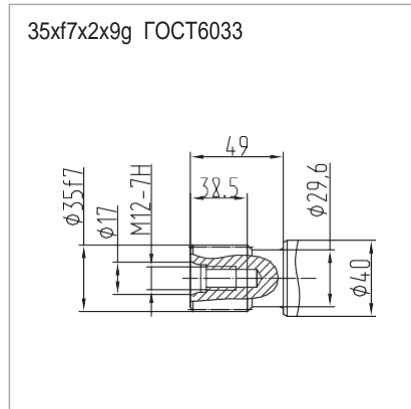
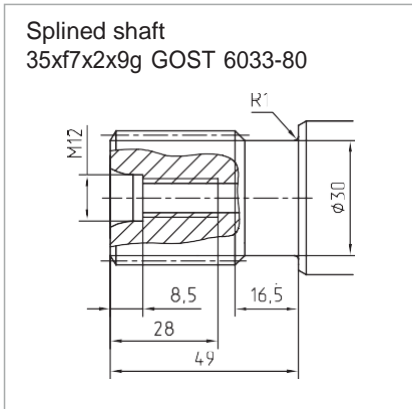

Direction of Rotation; Reversible

The Pumps rotate clockwise or counter-clockwise depending on the direction of hydraulic flow entering the Pump.

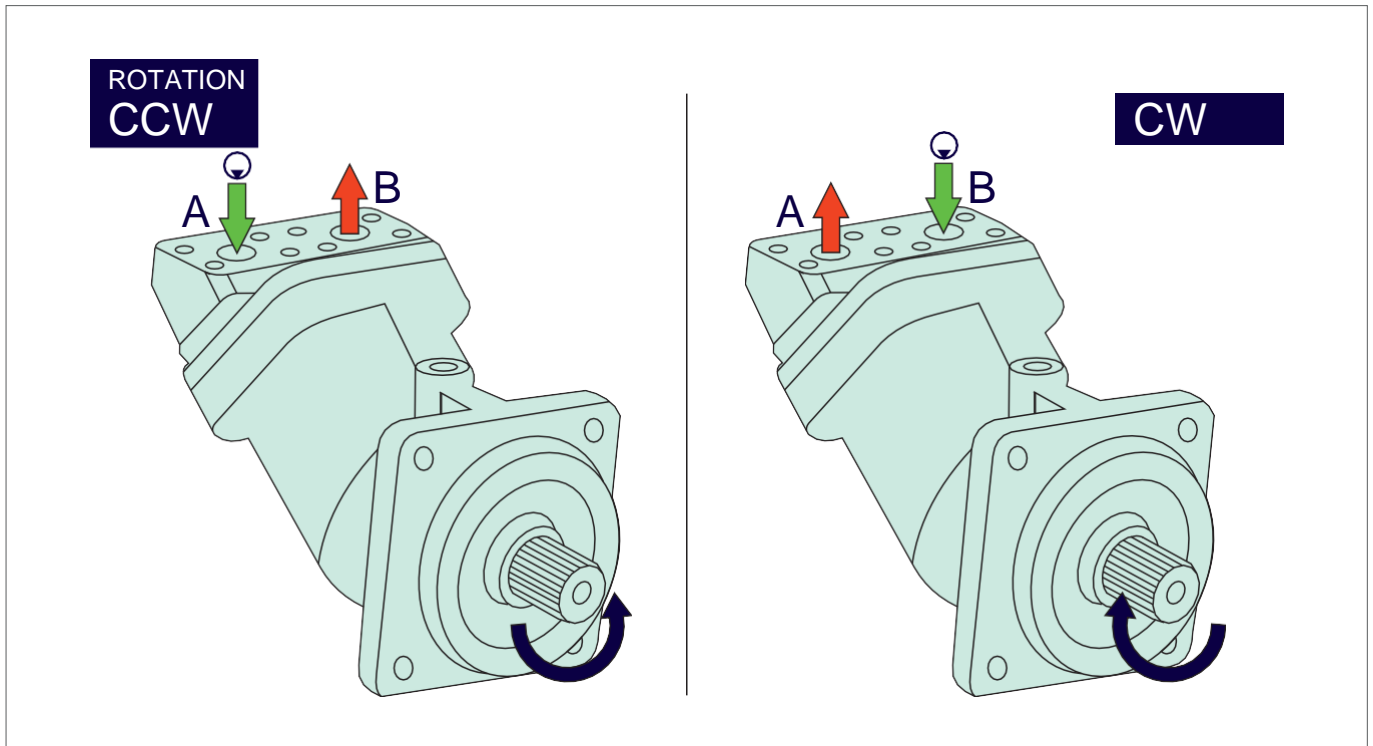

Formulas			
Pump Output Flow	GPM	$GPM = (\text{Speed (rpm)} \times \text{disp. (cu. in.)}) / 231$	$GPM = (n \times d) / 231$
Pump Input Horsepower	HP	$HP = GPM \times \text{Pressure (psi)} / 1714 \times \text{Efficiency}$	$HP = (Q \times P) / 1714 \times E$
Pump Efficiency	E	Overall Efficiency = Output HP / Input HP	$E_{\text{Overall}} = \text{HPOut} / \text{HPIn} \times 100$
		Overall Efficiency = Volumetric Eff. \times Mechanical Eff.	$E_{\text{Overall}} = \text{EffVol.} \times \text{EffMech.}$
Pump Volumetric Efficiency	E	Volumetric Efficiency = Actual Flow Rate Output (GPM) / Theoretical Flow Rate Output (GPM) \times 100	$\text{EffVol.} = \text{QAct.} / \text{QTheo.} \times 100$
Pump Mechanical Efficiency	E	Mechanical Efficiency = Theoretical Torque to Drive / Actual Torque to Drive \times 100	$\text{EffMech} = \text{TTheo.} / \text{TAct.} \times 100$
Pump Displacement	CIPR	$\text{Dsplcmnt (In.}^3 \text{ / rev.)} = \text{Flow Rate (GPM)} \times 231 / \text{Pump RPM}$	$\text{CIPR} = \text{GPM} \times 231 / \text{RPM}$
Pump Torque	T	Torque = Horsepower \times 63025 / RPM	$T = 63025 \times \text{HP} / \text{RPM}$
		Torque = Pressure (PSIG) \times Pump Displacement (CIPR) / 2 π	$T = P \times \text{CIPR} / 6.28$

Horsepower for driving a pump : For every 1 hp of drive, the equivalent of 1 gpm @ 1500 psi can be produced.

Horsepower for idling a pump : To idle a pump when it is unloaded will require about 5% of it's full rated power

Wattage for heating hydraulic oil : Each watt will raise the temperature of 1 gallon of oil by 1° F. per hour.

Flow velocity in hydraulic lines : Pump suction lines 2 to 4 feet per second, pressure lines up to 500 psi - 10 to 15 ft./sec., pressure lines 500 to 3000 psi - 15 / 20 ft./sec.; all oil lines in air-over-oil systems; 4 ft./sec.

Installation & Assemble Informations for Bent Axis Pumps

POSITION

ISO Flange Bent Axis Pumps can be operate any position.

DIRECTION OF ROTATION

ISO Flange Bent Axis Pumps can be operate in both directions of rotation.

Before of Installation operation, the Pump must be filled with hydraulic fluid and air bled.

INSTALLATION POSITION

See following examples.

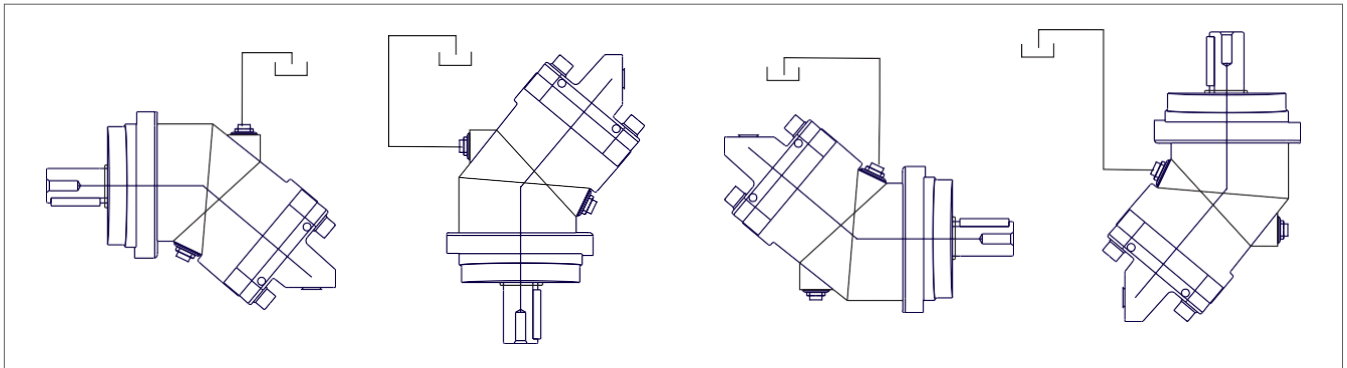

HYDRAULIC FLUID

Recommended ;

Generally : between 15 and 200 cSt.

Maximum : between 5 and 1600 cSt.

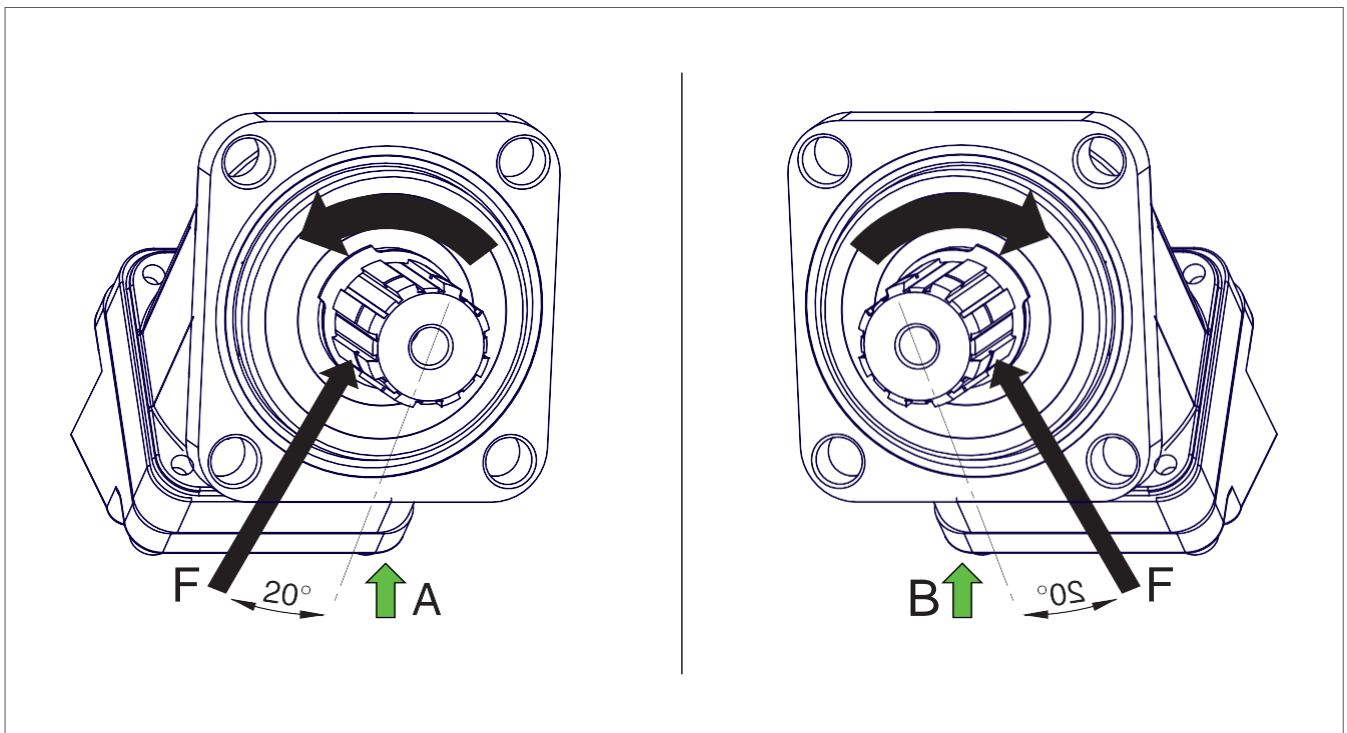

FOR USE;

Available via e-mail on request or each Pump is supplied via Starting datasheet.

Formulas, Calculations, Installation Guide

Quick Calculation

Flow rate

$$Q = \frac{V_s \cdot n}{1000 \eta_v} \text{ (lpm)}$$

Torque

$$M = \frac{V_s \cdot \Delta p \cdot \eta_{mh}}{63} \text{ (Nm)}$$

Power

$$P = \frac{2\pi \cdot M \cdot n}{60000} = \frac{M \cdot n}{9549} = \frac{Q \cdot \Delta p \cdot \eta_t}{600} \text{ (kw)}$$

Speed

$$n = \frac{1000 \cdot Q \cdot \eta_v}{V_s} \text{ (lpm)}$$

- V_s = Displacement (ccm/rev.)
 p = Diff. pressure (bar)
 n = Speed (rpm)
 Q = Flow (lpm)
 η_v = Volumetric efficiency
 η_{mh} = Mechanical-hydraulic efficiency
 η_t = Total efficiency ($\eta_t = \eta_v \times \eta_{mh}$)

New frame sizes to meet market requirements.

Optional by-pass valve.

For use in mobile & industrial and stationary applications areas.

The pump drive shaft bearings are designed to give the service life expected in these areas of operation. Interchangeable with other bent axis pumps & Pumps

40° bent axis design giving high power, small overall dimensions, optimum efficiency and economic design. Flange and shaft designed for direct mounting on truck gearbox PTO's. The fixed displacement bent axis pumps generates a hydraulic fluid flow. It is designed for use in trucks, commercial vehicles and all stationary hydraulic applications. The pump is a fixed pump with rotary group in bent-axis design open circuits. Flow is proportional to drive speed and displacement.

For axial piston units with bent-axis design, the Pistons are arranged diagonally with respect to the drive shaft. The pump motor covers the whole displacement range 5 to 130 cm³/rev. The pump has been developed with modern styling and design to satisfy market demand as to designed new generation plate and pistons with give high flow performance, high pressures with high efficiency and very small dimensions.

The pump is available both to DIN and SAE world standards and can be mounted either directly at the gear box or via a drive shaft. If necessary it can also be augmented with a by-pass valve.

Other brand bent axis pumps compatible and interchangeable with bent axis pumps motors. Refer to the data sheet and order confirmation for the technical data, operating conditions and operating limits of the bent axis piston pumps.

Complete Product Range

Bent Axis Piston Motors

K2FM (DIN) Bent Axis Motor
K3FH (HYBRID) Bent Axis Motor
A2MS (SAE) Bent Axis Motor
A3MS (SAE2) Bent Axis Motor
A2FM (ISO) Bent Axis Motor

A2FE (Fixed Plugin) Bent Axis Motor
A2FE (Two Speed) Bent Axis Motor
A2FT 45 (Inline) Bent Axis Motor

Bent Axis Piston Pumps

K2FA (DIN) Bent Axis Pump
K2FH (HYBRID) Bent Axis Pump
K2FL (Aluminum) Bent Axis Pump
A2FS (SAE) Bent Axis Pump
A3FS (SAE2) Bent Axis Pump
A2FO (ISO) Bent Axis Pump
A3FO (ISO2) Bent Axis Pump
A2FP (Fixed Plugin) Bent Axis Pump

Variable Displacement Motors

AXMV Variable Piston Motor
AXMA Variable Piston Motor
AXMI Variable Piston Motor

Variable Displacement Pumps

AXVP Variable Piston Motor
AXVA Variable Piston Motor
AXVI Variable Piston Motor

Dual Flow Piston Pumps

A2FD (DIN) Dual Flow Pumps
A2FD (SAE) Dual Flow Pumps
A2PD Axial Dual Output Pumps

Axial Piston & Gear Pumps

A3PP Axial Piston Pumps
A3PH High Pressure Pumps
A2GP Gear Pumps
A2GPT Tandem Gear Pumps
A2GM Gear Motors

A2GMT Tandem Gear Motors

Valve (ByPass) (Flushing) (Cavitation)

Circulation Valve
ByPass Valve
Anti-Cavitation Valve
Flushing Valve
LS Valve
AntiShock Valve
Speed Sensor

Hydraulic Spare Parts

Suction Fittings
Couplars
Adapters
Flanges
Power Take Off
Monoblock Valve
Section Valve