

Data Sheet

# H1P 069/078

## Axial Piston Single Pumps



For more than 40 years, Danfoss has been developing state-of-the-art components and systems for mobile machinery used in off-highway operations around the world.

We have become a preferred supplier by offering the best of what really matters: The hardware inside your vehicle application.

The H1 range is built around an advanced control and available in a wide range of displacements. It is designed for quality and reliability and offers expanded functionality, greater total efficiency, and easy installation.

All H1 control and sensor options are PLUS+1<sup>®</sup> Compliant. PLUS+1<sup>®</sup> allows you to rapidly develop and customize electronic machine control. It opens up the future by combining machine controls and diagnostics in an integrated operating network.

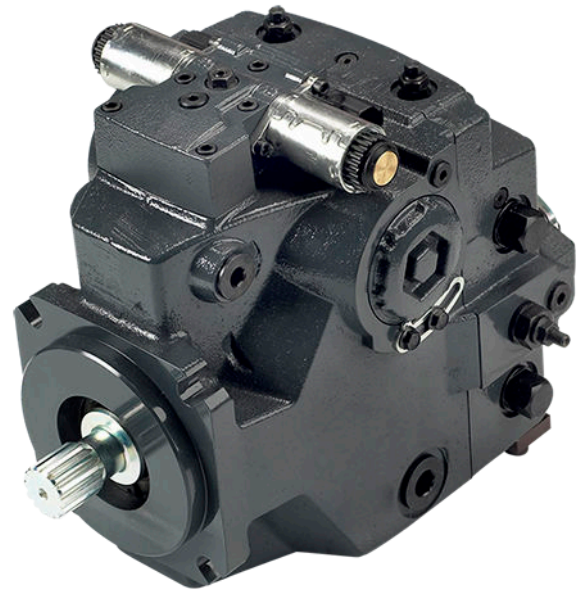

### Features

#### Designed for quality and reliability

- One design concept
- Single piece swash plate

#### Wide range of controls

- Electro-hydraulic controls:
  - Electrical Displacement Control (EDC)
  - Forward-Neutral-Reverse (FNR)
  - Non-Feedback Proportional Electric (NFPE)
- Automotive Control (AC)
- Fan Drive Control (FDC)
- Manual Displacement Control (MDC)
- Hydraulic Displacement Control (HDC)
- Common control across entire family

#### Greater total efficiency

- Minimized control losses
- Improved charge circuit
- Lower control pressure for less power consumption

#### Installation and packaging benefits

- Length optimized pump
- Minimum one clean side
- Higher corner HP / package size ratio
- Standardized connector interface

#### Expanded functionality

- PLUS+1<sup>®</sup> Compliant control and sensor options
- Integral filtration available with integrated filter bypass sensors and switch

For more information see the H1P 069/078 Axial Piston Single Pumps Technical Information, **BC0000058**.

Comprehensive technical literature is online at [www.danfoss.com](http://www.danfoss.com)

**Technical Specifications**

Parameters		Size 069	Size 078
<b>Displacement</b> cm <sup>3</sup> [in <sup>3</sup> ]		69.2 [4.22]	78.1 [4.77]
<b>Input speed</b> min <sup>-1</sup> (rpm)	Minimum	500	
	Rated	3500	
	Maximum	4000	
<b>System pressure</b> bar [psi]	Max. working*	450 [6527]	
	Maximum	480 [6962]	
	Min. low loop	10 [145]	
<b>Case pressure</b> bar [psi]	Rated	3.0 [44.0]	
	Maximum	5.0 [73.0]	
<b>Weight</b> (without PTO and filter), kg [lb]		56 [123]	

\* Pressures above max. working pressure requires Danfoss approval.

**Schematic**

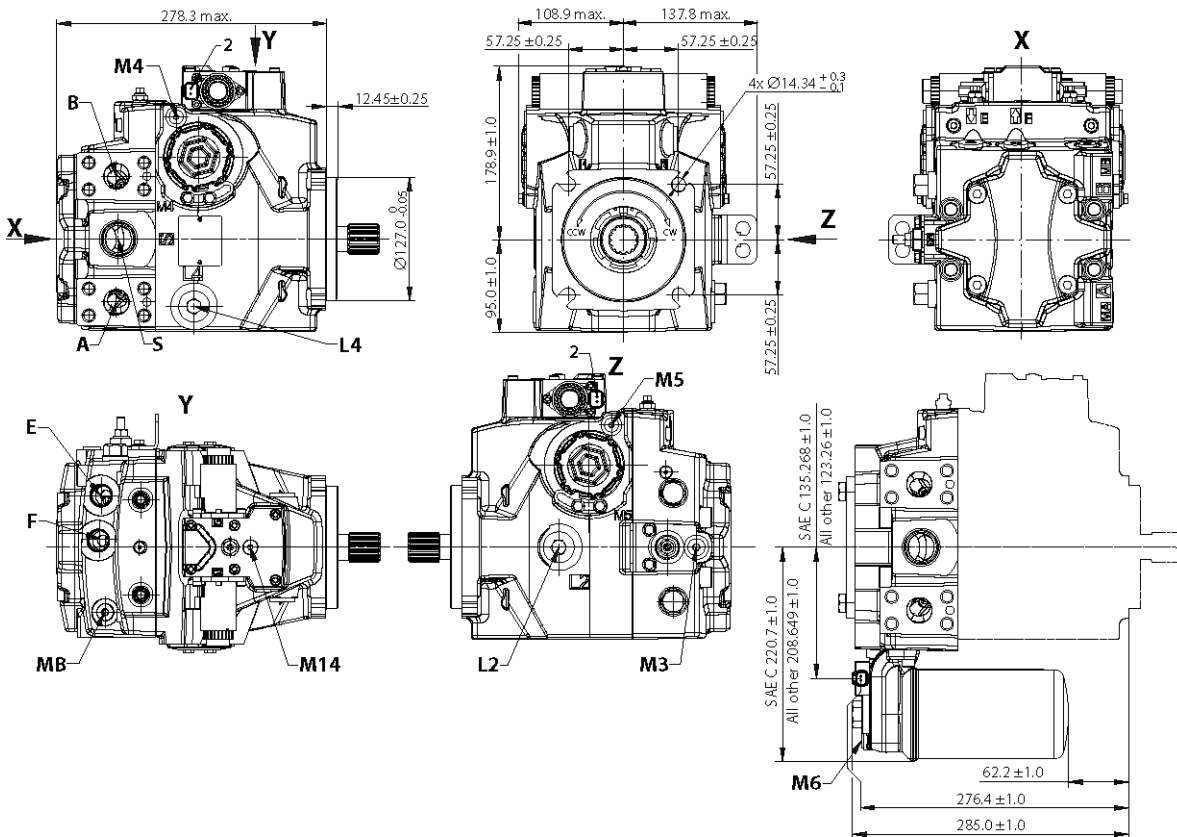
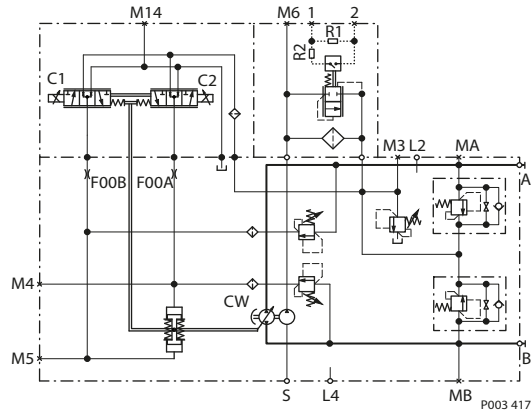

**A/B** system ports: Ø25.4 – 450 bar, Split flange boss ISO 6162; M1 2x 1.75, 20 min full thread depth

**MA/MB** (system), **M3, M6** (charge) gauge ports per ISO 11926-1: 9/16-18

**M4, M5** (servo), **M14** (case) gauge ports per ISO 11926-1: 7/16-20

**L2, L4** – Case drain ports per ISO 11926-1: 1 1/16-12

**E/F** – Charge filtration ports per ISO 11926-1: 7/8-14

**S** – Charge inlet port per ISO 11926-1: 1 5/16-12

**2** – Connector DEUTSCH DT04-2P, to be paint free

Danfoss can accept no responsibility for possible errors in catalogues, brochures and other printed material. Danfoss reserves the right to alter its products without notice. This also applies to products already on order provided that such alterations can be made without subsequent changes being necessary in specifications already agreed. All trademarks in this material are property of the respective companies. Danfoss and the Danfoss logotype are trademarks of Danfoss A/S. All rights reserved.