

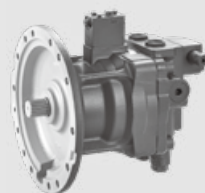

# HM5X SERIES

**Swash-plate Type  
Axial Piston Fixed Displacement Motor**

Size :	18	23	27	34	45	80	130	180	250
Rated pressure (bar) :	216	216	206	216	240	350	324	324	324
Max. pressure (bar) :	260	260	250	260	290	420	392	392	392



## Contents

Technical Data	02
Type introduction	03-04
Principle	
· HM5X 18/23/27/34/45	05
· HM5X 80/130/180/250	05
Installation size	
· HM5X 18	06-07
· HM5X 23	08-09
· HM5X 27	10-11
· HM5X 34	12-13
· HM5X 45	14-15
· HM5X 80	16-17
· HM5X 130	18-19
· HM5X 180	20-21
· HM5X 250	21-22

HM5X series swashplate axial piston motor is fixed displacement motor, with wide application for high pressure open circuit.

The design provides for an extraordinarily compact motor whereby the motor's rotating group, integral mechanical brake element and the attached valve options are neatly packaged together. Assembling the mechanical brake around the rotating group means that there is no configurational difference in motor installation which allows the optional provision of a brake.

## Features

### HM5X 18/23/27/34/45:

- Swashplate type piston motor, integrated with mechanical brake, buffered relief valve, charge valve.
- Compact structure design with the motor's rotating group, integral mechanical brake element and the attached valve options.
- Special design of the mounting flange, can be directly connected with the ring gear of the reduction gear box.
- The motor and reduction gear box apply with the hydraulic oil lubrication method, reducing the maintenance cost of reducer.
- Applied in small excavators and other mobile machinery.

### HM5X 80/130/180/250:

- Swashplate type piston motor, integrated with mechanical brake, relief valve, charge valve and anti-reaction valve;
- Compact structure design with the motor's rotating group, integral mechanical brake element and the attached valve options are neatly packaged together.
- Special design of the mounting flange, can be directly connected with the reducer.
- Structure is improved of light weight and compact based on the mature technology, increased the output power.
- Applied in the rotation condition of excavators and drilling rigs, etc.

## Technical Data

Feature	18	23	27	34	45	80	130	180	250	
Max displacement (cc/rev)	18.1	23.6	27.4	34	44.1	79	129.2	149 169 180	250.1	
Direction of rotation	Clockwise, Counter clockwise									
Rotation speed	Max (rpm)	2150	1000	1605	1760	1760	2200	1850	1680	1520
Pressure	Rated (bar)	216	216	206	216	240	350	324	324	324
	Max (bar)	260	260	250	260	290	420	392	392	392
Torque	Rated output torque (N·m)	62	63	89.5	113	168.5	440	670	932	1290
	Max. brake torque (N·m)	68	-	90	125	178	423	843	1250	1470
Rated output power (Kw)		14	6.6	15.1	20.8	31	101	129	163	205
Barking Pilot Pressure	Normal (bar)	25	-	15	29	15	22	34	34	34
	Max (bar)	49	-	39	49	49	49	49	49	49
Casting pressure	Rated (bar)	2	1	1	1	1	2	2	2	2
	Max (bar)	3	3	3	3	3	6	6	6	6
Reduction ratio		21.5	10	22.7	21.5	20.615	—	—	—	—
Weight (Kg)		37	23	50	53	84.7	38	55	61	100
		Containing Reduction gear								
Oil viscosity (mm <sup>2</sup> /s)		7~1600, Best range: 12~80								
Oil Temperature (°C)		-40~100, Best range: 60~85								
Oil Cleanliness		ISO 4406 22/18/13								

When the viscosity is within 200 ~ 1000mm<sup>2</sup>/s, need to preheat before formal running.

Note: The HM5X18, HM5X23, HM5X27, HM5X34 and HM5X45 series hydraulic motor is delivered with reducer.

The above mentioned data represents the motor data only.

For the assembly data the reducer data shall be considered.

## Type introduction (1)

HMSX	027	0	0	2060	L	27P
①	②	③	④	⑤	⑥	⑦

### Product series

①	Swashplate piston fixed motor	HMSX
---	-------------------------------	------

### Displacement

②	Displacement cc/rev	18	23	27	34	45
---	---------------------	----	----	----	----	----

### Time delay valve

③	With Time delay valve	1
	Without Time delay valve	0

### Anti-reaction valve

④	With Anti-reaction valve	1
	Without Anti-reaction valve	0

### Relief valve setting

⑤	Relief valve setting	
---	----------------------	--

### Special code

⑥	Special code	
---	--------------	--

### Reducer type

⑦	Suitable for 18 displacement motor	3B
	Suitable for 23 displacement motor	1B
	Suitable for 27 displacement motor	27P
	Suitable for 34 displacement motor	4B
	Suitable for 45 displacement motor	45P

## Type introduction (2)

HM5X	130	C	H	B	-	10	A	-	01A	/	***	-	***
①	②	③	④	⑤		⑥	⑦		⑧		⑨		⑩

### Product series

①	Swashplate piston fixed motor	HM5X
---	-------------------------------	------

### Displacement

②	Displacement cc/rev	80	130	180	250
---	---------------------	----	-----	-----	-----

### Structure Type

③	Standard Type	C
---	---------------	---

### Built-in device combination code

④	Built-in device combination code	H
---	----------------------------------	---

### Accessory device

⑤	None	O
	With mechanical brake	B

### Shaft end shape

⑥	Convex shaft	10
	Concave shaft	20

### Technical standard

⑦	Shaft standard	A
---	----------------	---

### Special code

⑧	Special code	
---	--------------	--

### Pressure reducing valve setting

⑨	Pressure reducing valve setting	
---	---------------------------------	--

### Displacement setting

⑩	Displacement setting	
---	----------------------	--

# Principle

## • HM5X 18

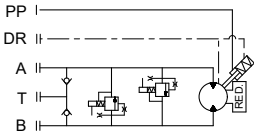

## • HM5X 23

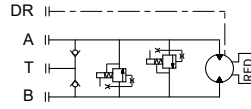

## • HM5X 27

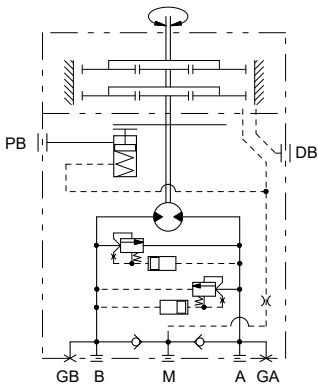

## • HM5X 34

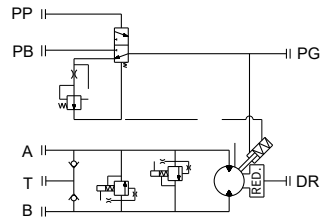

## • HM5X 45

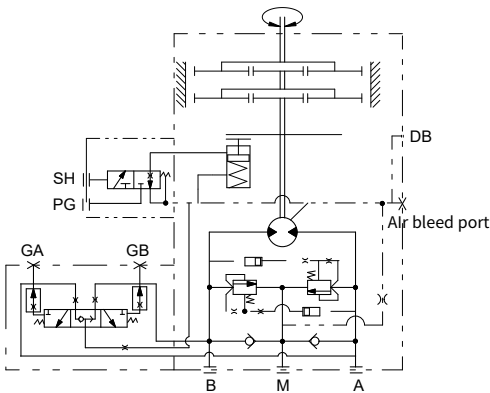

## • HM5X 80 / 130 / 180 / 250

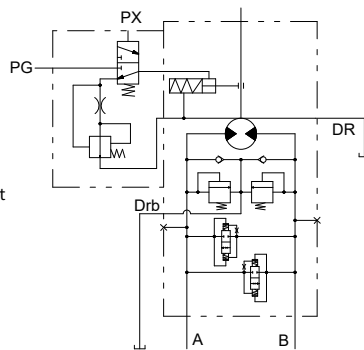

# Installation size

## • HM5X 18 Installation size

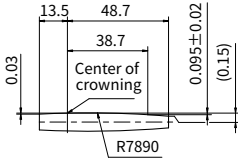

Detail of crowning

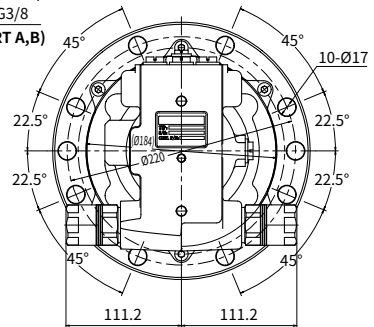
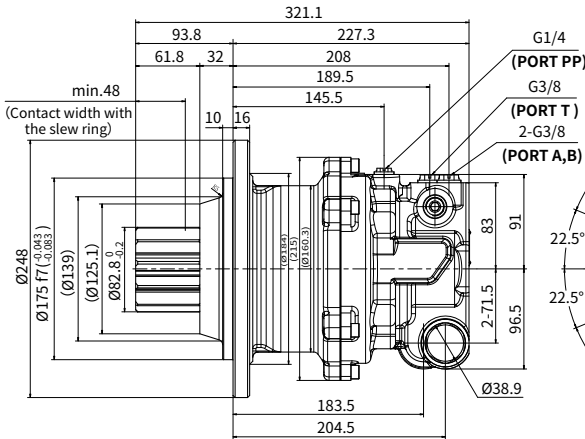
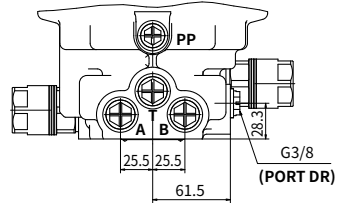

Inlet port	Outlet port	Rotation direction
B	A	Clockwise
A	B	Anti-clockwise

**Note:** The rotation direction is looked from the shaft end.

## Installation size

### • HMSX 18 Port details

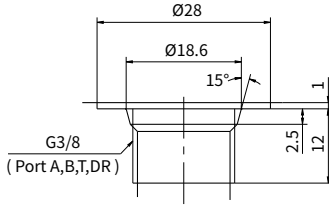

Detailed description of G3/8  
(Port A,B,T,DR)

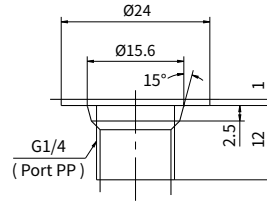

Detailed description of G1/4  
(Port PP)

	Port Name	Port Size and Description	Tightening Torque (N·m)
A B	Inlet port and Delivery port	G3/8 ( depth 12mm )	70
T	Charge port	G3/8 ( depth 12mm )	70
DR	Housing drain port	G3/8 ( depth 12 mm )	70
PP	Braking release pilot port	G1/4 ( depth 12 mm )	45

### • Specifications of output pinion

Module	m=6
No.Of teeth	Z=11
Addendum mod.	X=0.5
Displacement over teeth	29.546 <sup>-0.080</sup> <sub>-0.180</sub> (Measurements with two teeth)
Precision class	JIS Class 5
Pressure angle	a=20°

## Installation size

### • HM5X 23 Installation size

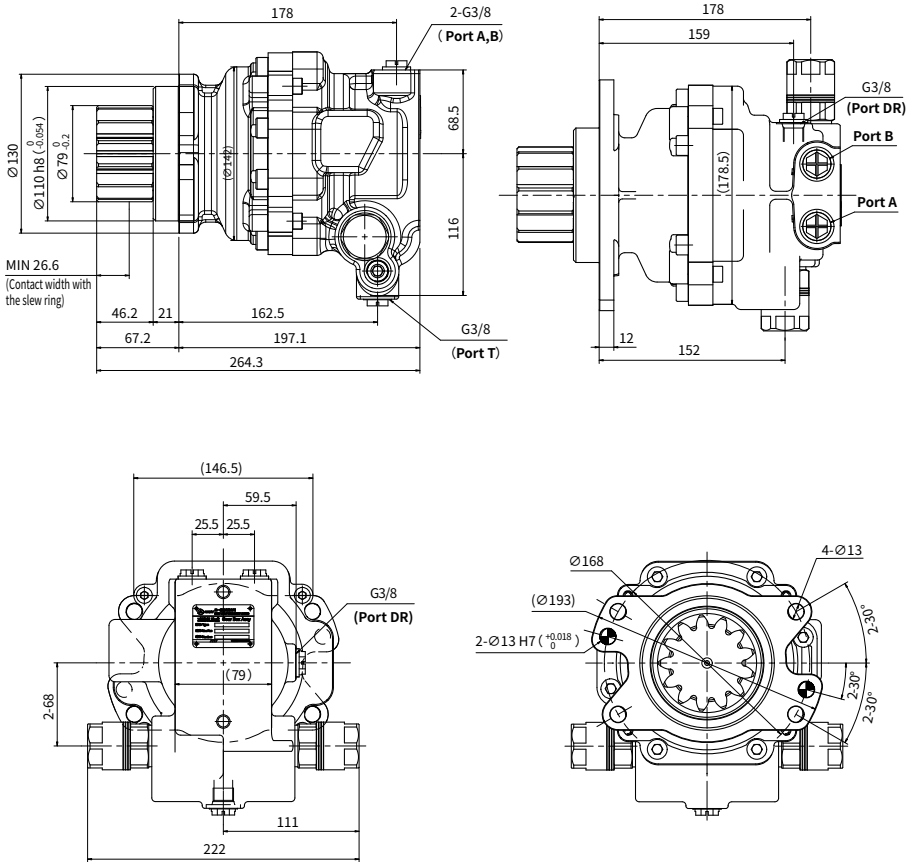

HM5X

Inlet port	Outlet port	Rotation direction
B	A	Clockwise
A	B	Anti-clockwise

**Note:** The rotation direction is looked from the shaft end.



## Installation size

### • HMSX 23 Port details

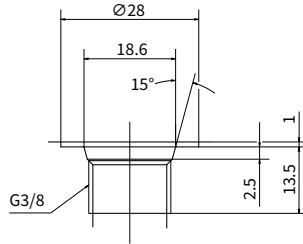

Detailed description of G3/8

	Port Name	Port Size and Description	Tightening Torque (N-m)
A	Inlet port and Delivery port	G3/8 ( depth 12mm )	70
B			
T	Charge port	G3/8 ( depth 12mm )	70
DR	Housing drain port	G3/8 ( depth 12 mm )	70

### • Specifications of output pinion

Module	m=5
No.Of teeth	Z=13
Addendum mod.	X=0.5
Displacement over teeth	39.522 <sup>-0.070</sup> / <sub>-0.170</sub> (Measurements with two teeth)
Precision class	JIS Class 5
Pressure angle	a=20°

# Installation size

## • HM5X 27 Installation size

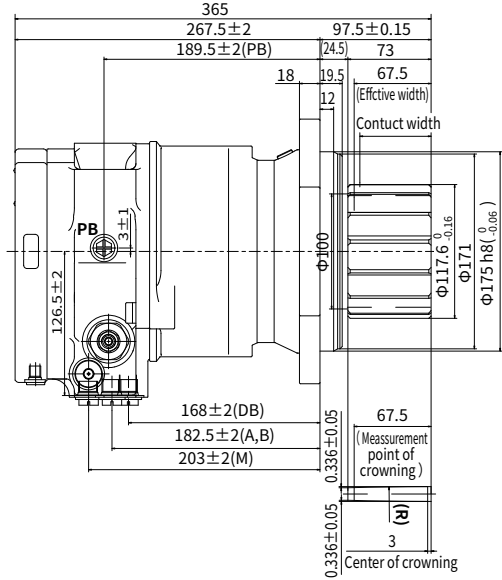
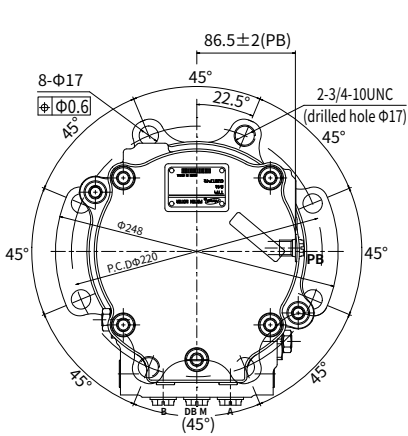

Inlet port	Outlet port	Rotation direction
A	B	Clockwise
B	A	Anti-clockwise

**Note:** The rotation direction is looked from the shaft end.

# Installation size

## • HMSX 27 Port details

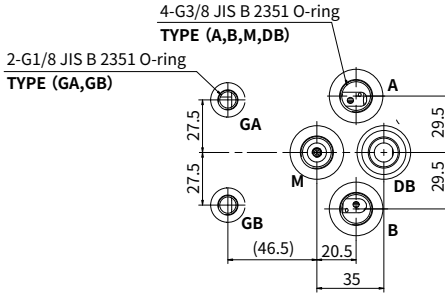

	Port Name	Port Size and Description	Tightening Torque (N·m)
A	Inlet port and Delivery port	G3/8( depth 15mm )	70
B			
M	Charge port		70
DB	Housing drain port	G3/8( depth 15 mm )	70
PB	Braking release pilot port	G1/4( depth 12 mm )	45
GA	Gauge port of "A" and "B"	G1/8( depth 12 mm )	13
GB			

## • Specifications of output pinion

Spar gear		
Tool	Tooth profile	Standard gear
	Module	7
	Pressure angle	20°
No. of teeth		14
Pitch diameter		Φ98.00
Addendum mod.		+2.80( X=+0.4 )
Tooth thickness	Displacement over teeth	54.950( <sup>0</sup> <sub>-0.155</sub> )
	No.Of teeth	3
Precision class		JIS Class 5
Tooth surface roughness		3.2 ✓

# Installation size

## • HM5X 34 Installation size

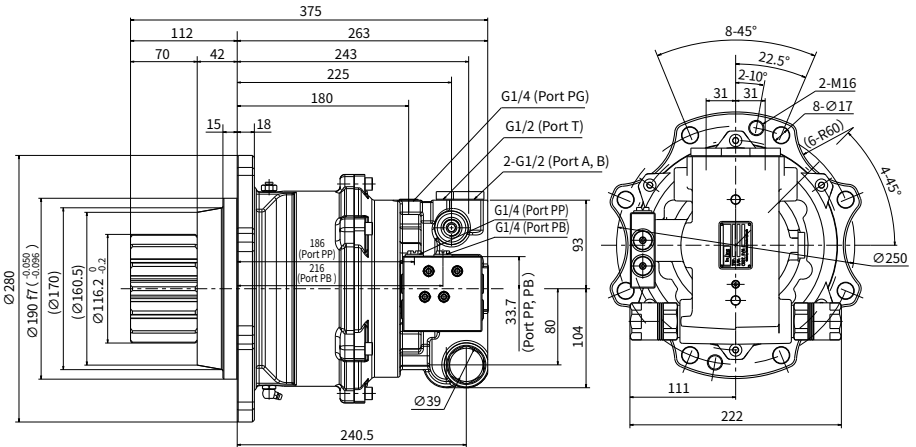
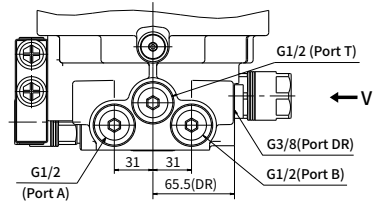
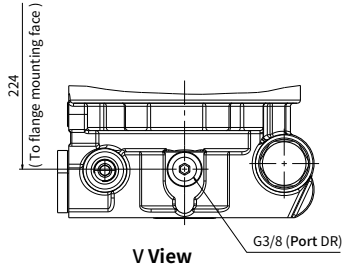

Inlet port	Outlet port	Rotation direction
B	A	Clockwise
A	B	Anti-clockwise

**Note:** The rotation direction is looked from the shaft end.

## Installation size

### • HMSX 34 Port details

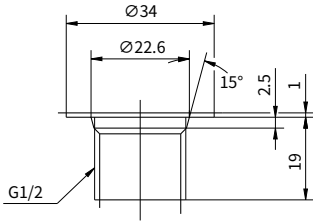

Detailed description of G1/2  
(Port A,B,T)

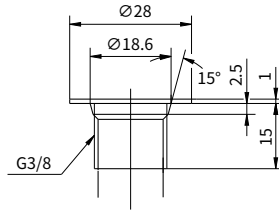

Detailed description of G3/8  
(Port DR)

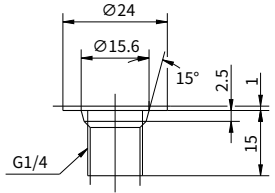

Detailed description of G1/4  
(Port PP,PB,PG)

	Port Name	Port Size and Description
A	Inlet port and Delivery port	G1/2 ( depth 19mm )
B		
T		
DR	Housing drain port	G3/8 ( depth 15 mm )
PP	Braking release pilot port	G1/4 ( depth 15 mm )
PB		

### • Specifications of output pinion

Spar gear		
Tool	Tooth profile	Standard gear
	Module	7
	Pressure angle	20°
No. Of teeth		14
Pitch diameter		∅ 98.00
Addendum mod.		+2.80 ( X=+0.4 )
Tooth thickness	Displacement over teeth	54.950 <sup>(-0.090)</sup> <sub>(-0.190)</sub>
	No.Of teeth	3



## Installation size

### • HMSX 45 Port details

	Port Name	Port Size and Description	Tightening Torque (N-m)
A	Inlet port and Delivery port	G1/2 ( depth 16mm )	109
B			
M	Charge port	G3/4 ( depth 17 mm )	200
DB	Housing drain port	G3/8 ( depth 12 mm )	70
PG	Braking pilot port	G1/4 ( depth 12 mm )	39.2
SH	Braking release control port		
GA、GB	Gauge port	G1/4 ( depth 12 mm )	39.2

### • Specifications of output pinion

#### Spar gear

Tool	Tooth profile	Standard gear
	Module	8
	Pressure angle	20°
No. Of teeth	12	
Pitch diameter	Φ96	
Addendum mod.	4.4 ( X=+0.55 )	
Tooth thickness	Displacement over teeth	39.780 <sup>-0.083</sup> / <sub>-0.189</sub> (Measurements with two teeth)
Reduction in tooth thickness	0.088 ~ 0.201	
Precision class	JIS B 1702-1976 Class 5	
Tooth surface roughness	3.2	





## Installation size

### • HMSX 80 Port details

	Port Name	Port Size and Description	Tightening Torque (N-m)	Plug type
A, B	Inlet port and Delivery port	G1/2 ( depth 19mm )	108	G1/2 Plastic plug
M	Charge port	G3/4 ( depth 20mm )	167	G3/4 Plastic plug
PA, PB	Gauge port	G1/4 ( depth 15 mm )	36	G1/4 Steel plug
DB	Housing drain port	G3/8 ( depth 15 mm )	74	G3/8 Plastic plug
PG	Braking release port	G1/4 ( depth 12 mm )	36	G1/4 Plastic plug
SH	Braking pilot port	G1/4 ( depth 12 mm )	36	G1/4 Plastic plug
L	Oil level port	Rc1/4-12.5	22	Steel plug
IP	Gear oil filling port	Rc1-22	127	Steel plug

### • HMSX 80 Shaft specification

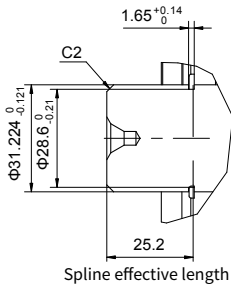

Involute spline 14-12/24DP	
Side fit	
Spline pitch	12/24
No. Of teeth	14
Pressure angle	30°
Major diameter	Ø31.224 <sup>0</sup> <sub>-0.16</sub>
Minor diameter	Ø26.993 <sup>0</sup> <sub>-0.2</sub>
Pitch diameter	Ø29.634
Base diameter	Ø25.663
Diameter of pina	Ø4.064
Spacing of pina	Ø35.719 ~ Ø35.783
Reference tooth thickness	3.230 ~ 3.273
Lead tolerance	0.015
Spline standard	SAE J498B



## Installation size

### • HM5X 130 Port details

	Port Name	Port Size and Description	Tightening Torque (N·m)
A	Inlet port and Delivery port	G3/4 ( depth 20mm )	320
B			
Drb	Charge port		200
DR	Housing drain port	G3/8 ( depth 15 mm )	70
PG	Braking pilot port	G1/4 ( depth 12 mm )	45
PX	Braking release control port		

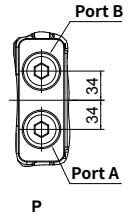

### • HM5X 130 Shaft specification

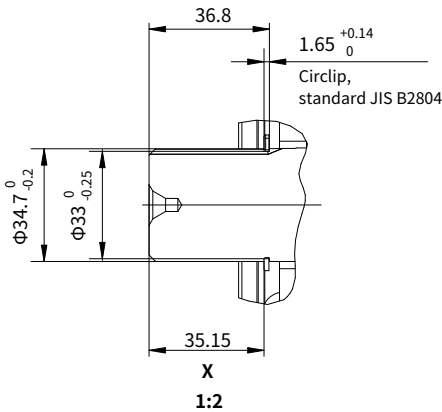

Spline standard	JIS D2001
Number of teeth	19
Module	1.667



## Installation size

### • HM5X 180 Ports size

(Exclude Inlet and Delivery ports)

	Port Name	Port Size and Description	Tightening Torque (N-m)
M	Charge port	G1( depth 24mm )	200
DR	Housing drain port	G1/2( depth 23mm )	109
PG	Braking release port	G1/4( depth 12mm )	36
SH	Braking pilot port	G1/4( depth 12mm )	36
PA, PB	Pressure measuring	G1/4( depth 15mm )	36

### • HM5X 180 Inlet and Delivery ports options

(P direction)

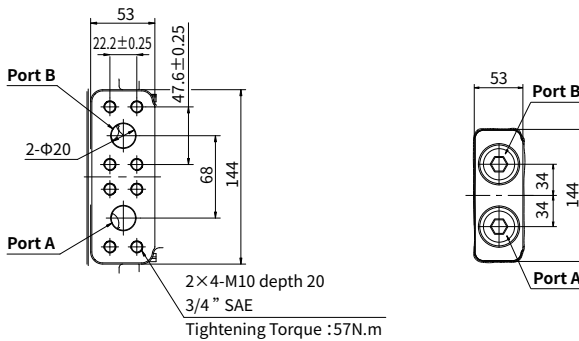

	Port Name	Port Size and Description	Tightening Torque (N-m)
Flanged type	A	Inlet port and Delivery port	SAE G3/4
	B		
Threaded type	A	Inlet port and Delivery port	G3/4( depth 20mm )
	B		

## Installation size

### • HM5X 180 Shaft specification

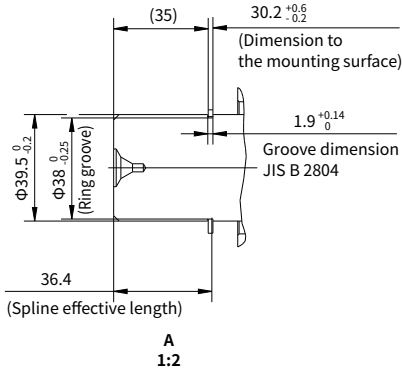

Spline standard	JIS D2001
Number of teeth	14
Module	2.5

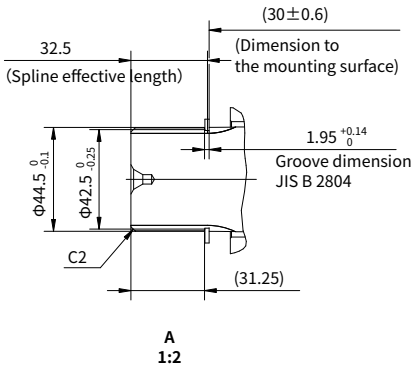

Spline standard	JIS D2001
Number of teeth	16
Module	2.5

# Installation size

## HM5X 250 Installation size

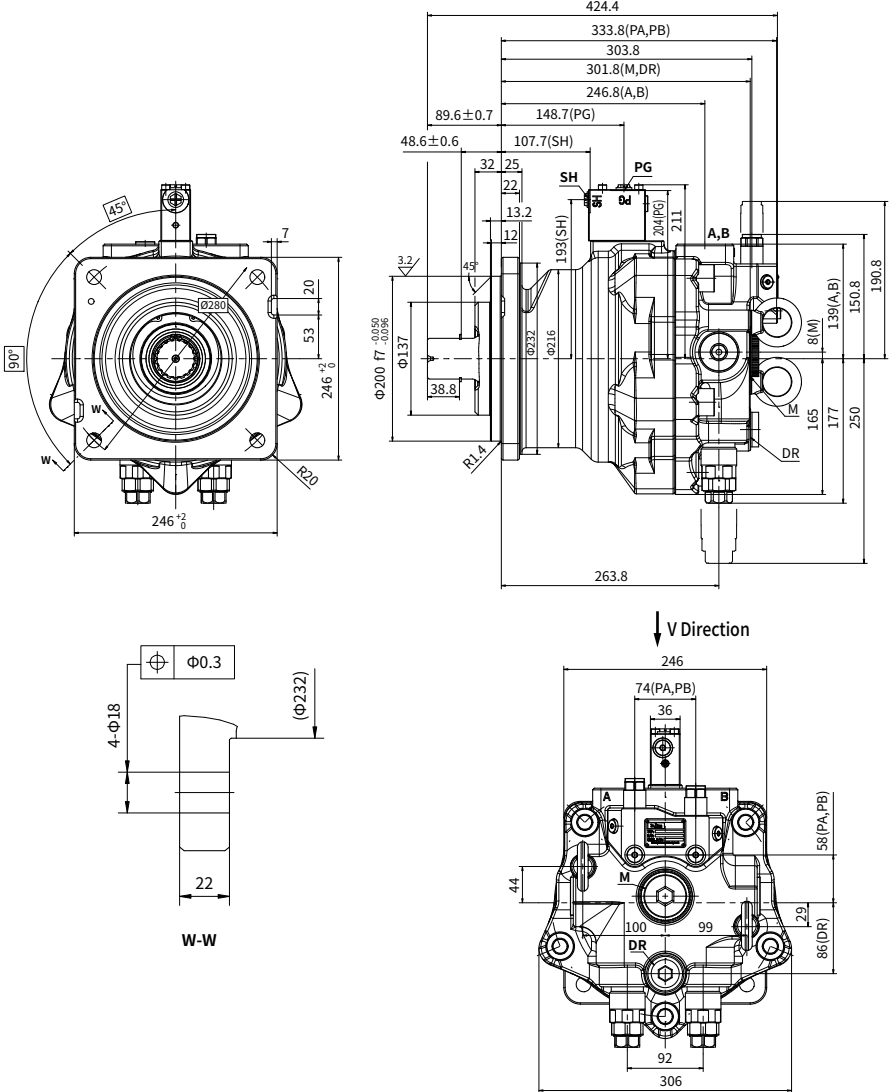

HMSX

## Installation size

### ·HM5X 250 Port details

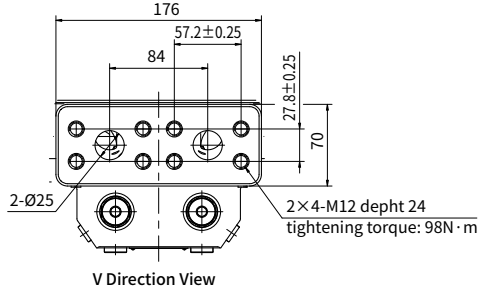

	Port Name	Port Size and Description	Tightening Torque (N·m)	Plug type
M	Charge port	G1 · 1/4	200	G1 Plastic plug
DR	Housing drain port	G3/4	109	G1/2 Plastic plug
PG	Braking release port	G1/4 ( depth 12 mm )	36	G1/4 Plastic plug
SH	Braking pilot port	G1/4 ( depth 12 mm )	36	G1/4 Plastic plug
PA , PB	Gauge port	G1/4 ( depth 15 mm )	36	G1/4 Steel plug

### ·Specifications of output pinion

Shaft spline 49.5×18×2.5		
Flat root and Side fit		
stand-off error	0.8	
Tool	Tooth profile	Substandard gear
	Module	2.5
	Pressure angle	20°
No. Of teeth	18	
Pitch diameter	Φ45	
Major diameter	Φ49.4 <sup>0</sup> <sub>-0.1</sub>	
Minor diameter	Φ44 <sup>0</sup> <sub>-0.1</sub>	
Diameter of pina	Φ4.5	
Spacing of pina	Φ54.366 <sup>-0.132</sup> <sub>-0.223</sub>	
Lead tolerance	0.04	
Precision class	Class a	
Spline standard	JIS D2001	

#### China

+86 400 101 8889

#### America

+01 630 995 3674

#### Germany

+49 (30) 72088-0

#### Japan

+81 03 6809 1696



© This brochure can be reproduced, edited, reproduced or transmitted electronically without the authorization of Hengli Hydraulic Company. Due to the continuous development of the product, the information in this brochure is not specific to the specific conditions or applicability of the industry, thus, Hengli does not take any responsibility for any incomplete or inaccurate description.