



# HP3G SERIES

## Swash-plate Type Axial Piston Variable Displacement Pump

HP3G series variable axial piston pump with swashplate design for hydrostatic drives in closed circuit, high pressure, high speed, high reliability, low noise, can be applied in engineering machinery and mobile machinery.

Applied in medium pressure closed circuit

Size:	28	32	46
Rated pressure (bar):	345	345	345
Max. pressure (bar):	380	380	385

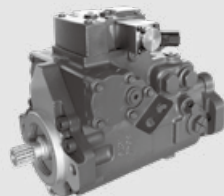

## Contents

Technical Data	02
Type introduction	03-05
Control mode	
· Manual displacement control (MDC)	06
· Electrical displacement control (EDC)	07
Pump principle & installation size	
· HP3G 28	08-11
· HP3G 32	12-15
· HP3G 46	16-19

## Features

- Variable axial piston pump of swashplate design for hydrostatic drives in closed circuit.
- The flow is proportional to the drive speed and displacement. The flow increases as the angle of the swashplate is adjusted from zero to its maximum value.
- Flow direction changes smoothly when the swashplate is moved through the neutral position.
- Two pressure-relief valves are provided on the high pressure ports to protect the hydrostatic transmission (pump and motor) from overload.
- The integrated charge pump can provide system replenishing and cooling fluid flow.
- High reliability, long working lifetime
- Compact structure, high power density.

## Technical data

Size		28	32	46
Displacement (cc/rev)		28	32	45.9
Speed	Rated (rpm)	3400	3400	3000
	Max. (rpm)	4000	4000	4100
	Min. (rpm)	500	500	500
Pressure	Rated (bar) (relative to Charge pressure)	345	345	345
	Max. (bar) (relative to Charge pressure)	380	380	385
	Min. low loop pressure(bar) (relative to Charge pump)	10	10	10
Charge pressure (relative to Charge pump)	Min. (bar)	16	16	6
	Max. (bar)	31	31	31
Control Pressure (relative to Charge pump)	Min. (bar) (EDC control)(bar)	24	24	21.5
Charge pump displacement (cc/rev)		12	12	13.9
Casting pressure	Rated (bar)	3	3	1.7
	Max. (bar)	5	5	5.2
Suction pressure ( Absolute pressure )	Rated (bar)	0.8	0.8	0.8
	Max. (bar)	2	2	6
Oil viscosity (mm <sup>2</sup> /s)		10~1000, Best range: 16~36		
Oil Temperature (°C )		-20~95		
Oil Cleanliness		ISO 4406 Class 18/13 or higher		
Weight ( w/o auxiliary flange ) (Kg)		33.3	32.3	33

## Type introduction

HP3G	46	A	R	A2	N	F	S2	B1	K28	B	P	J	PN	
①	②	③	④	⑤	⑥	⑦	⑧	⑨	⑩	⑪	⑫	⑬	⑭	⑮

### Product series

①	Variable piston pump of swashplate in closed circuit	HP3G
---	--	------

### Displacement

②	Displacement cc/rev	28	32	46
---	---------------------	----	----	----

### Product version

③	Series code	A
---	-------------	---

### Rotation

④	Right hand (clockwise)	R
	Left hand (counter-clockwise)	L

### Control

⑤		28	32	46	Code
	High current electric proportional displacement control (HC EDC), oil filled, deutsch DT04-2P, voltage 12V DC, control range: 300mA~950mA	●		●	A2
	High current electric proportional displacement control (HC EDC), oil filled, deutsch DT04-2P, voltage 24V DC, control range: 200mA~500mA	●		●	A4
	Manual displacement control, (control handle) -30° ~+30°		●		A3

### Displacement Limiters

⑥	Without displacement limiters	N
	With displacement limiters	M

### Mounting flange

⑦	ISO 3019-1, SAE B-2 hole (101-2)	F
---	----------------------------------	---

### Input shaft

⑧	SAE J744-25-4 15T 16/32DP	S2
	SAE J744-22-4 13T 16/32DP	S1

## Type introduction

### Through drive option

⑨	No through drive	NN
	SAE A 82-2 SAE J744-16-4 9T 16/32DP	A1
	SAE A 82-2 SAE J744-19-4 11T 16/32DP	A2
	SAE B 101-2 SAE J744-22-4 13T 16/32DP	B1

### Setting pressure of the high pressure relief valve

⑩—Overpressure protection type and setting side "A" and setting side "B"

⑩	High pressure relief valve setting  (differential pressure: relative to Charge pressure)	140 bar	K14
		175 bar	K17
		190 bar	K19
		210 bar	K21
		230 bar	K23
		250 bar	K25
		280 bar	K28
		320 bar	K32
		345 bar	K35

Please contact us for configurations or pressures not shown in above form.

### Charge pump

⑪		28	32	46	代号
	With charge pump, 13.9 cc/rev			●	B
	With charge pump, 12cc/rev	●	●		C

### Filtration Options

⑫	Remote pressure, with charge pump	P
	Suction, with charge pump	L

## Type introduction

### Setting pressure of the low pressure relief valve

⑬	21.5 bar	J
	19.5 bar	B
	24 bar	S
	26.9 bar	T

### Control orifice

⑭	Control orifice of Servo A&B $\phi$ 0.9mm	PN
	Control orifice of Servo A&B $\phi$ 1.4mm	RN
	Without control orifice	NN

### Paint and Nameplate

⑮	Black paint and Hengli nameplate	Blank
---	----------------------------------	-------

## Manual displacement control ( MDC)

The manual proportional displacement control (MDC) consists of a handle on top of a rotary input shaft.

The shaft provides an eccentric connection to a feedback link. This link is connected on its one end with a porting spool. On its other end the link is connected the pumps swashplate.

The MDC changes the pump displacement between no flow and full flow into opposite directions.

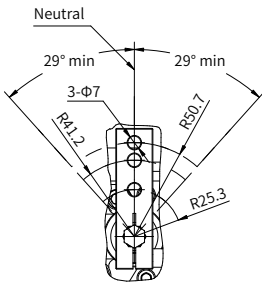

Schematic diagram of control joystick adjustment

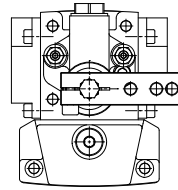

Control valve

## Electrical displacement control (EDC)

The High Current Electrical Displacement Control (HC EDC) consists of a pair of proportional solenoids on each side of a three-position, four-way porting spool. The proportional solenoid applies a force input to the spool, which ports hydraulic pressure to either side of a double acting servo piston. Differential pressure across the servo piston rotates the swashplate, changing the pump's displacement from full displacement in one direction to full displacement in the opposite direction.

A serviceable 125 µm screen is located in the supply line immediately before the control porting spool.

### Features:

- Precision parts provide repeatable accurate displacement settings with a given input signal.
- Both ends of the double acting servo piston are drained to case when input signal current is not present. The servo piston is coupled to a spring centering mechanism.

### Benefits:

- Simple, low-cost design.
- Pump will return to neutral after prime mover shuts down.
- Pump will return to neutral if external electrical input signal fails or if there is a loss of charge pressure

### • Pump displacement – control current

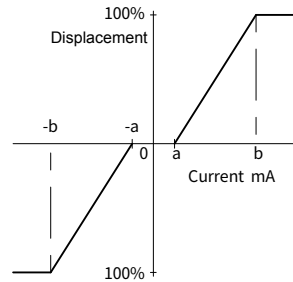

### • EDC Response time

Orifice diameter* mm [in]	Average response time [seconds]	
	Acceleration	Deceleration
1.2 [0.046]	2.0	1.6
None	0.9	1.0

\*Contact Hengli for special orifice combinations.

# HP3G28 Pump principle

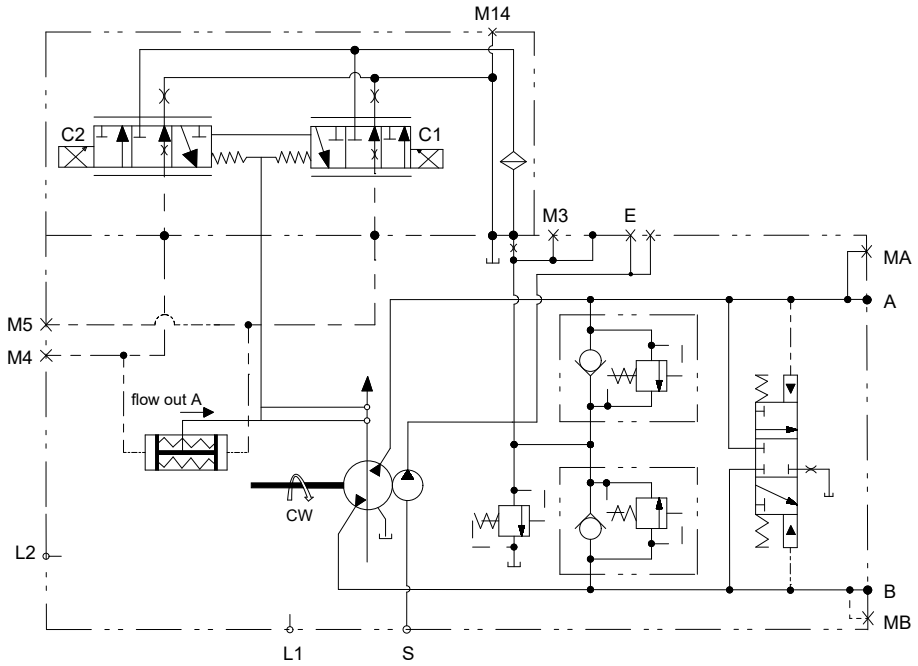

Input shaft rotation	CW		CCW	
	C2	C1	C2	C1
Energized coil	C2	C1	C2	C1
Oil port A	In	Out	Out	In
Oil port B	Out	In	In	Out
Servo pressure acting oil port	M5	M4	M5	M4

## Connector:

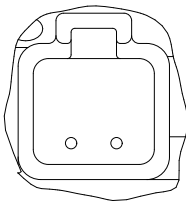

Deutsch DT04-2P  
 Voltage: 12V  
 V View

Refer to pump installation drawing for port locations.



# Installation size

## HP3G28 installation size

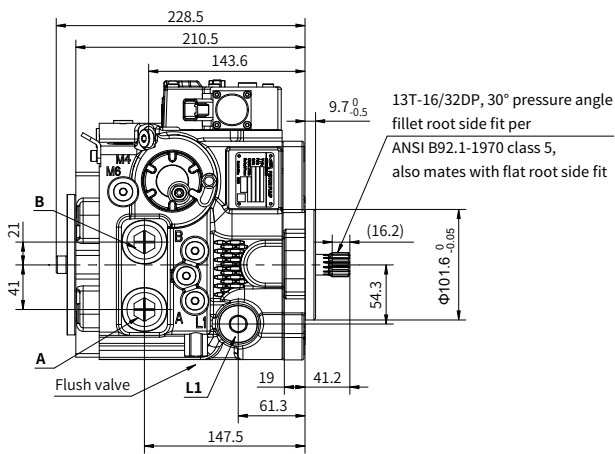
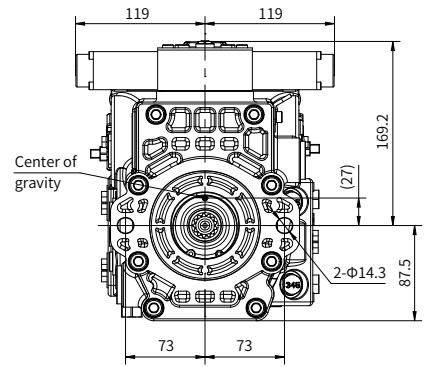
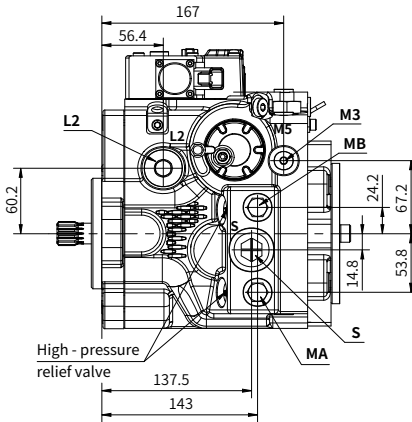
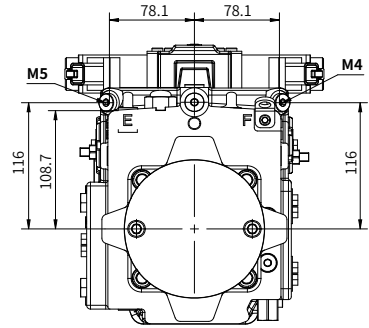
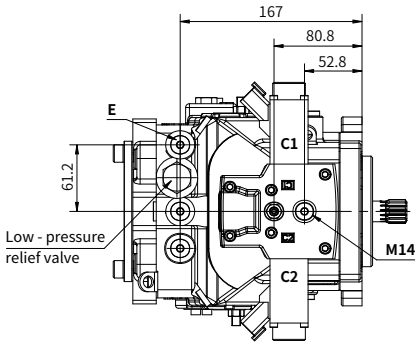

HP3G

## Installation size

### • HP3G28Port details

	Port Name	Port Size and Description	Tightening Torque(N.m)
S	Suction port	ISO 11926-1 ( 1 1/16-12UN )	101
A, B	Working port	ISO 11926-1 ( 1 1/16-12UN )	101
L1, L2	Drain port	ISO 11926-1 ( 1 1/16-12UN )	101
MA, MB	Port "A" and "B" gage port	ISO 11926-1 ( 9/16-18UNF )	25
M3	Gauge port of charge pump	ISO 11926-1 ( 9/16-18UNF )	25
E	External control port	ISO 11926-1 ( 9/16-18UNF )	25
M4, M5	Servo gage port	ISO 11926-1 ( 7/16-20UNF )	15
M14	Air bleed port	ISO 11926-1 ( 7/16-20UNF )	15

## Installation size

### HP3G28 Mounting Flange

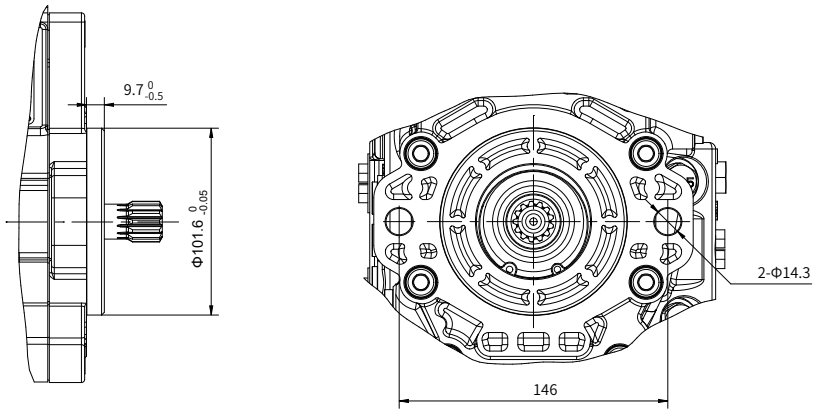

### HP3G28 Input Shaft type

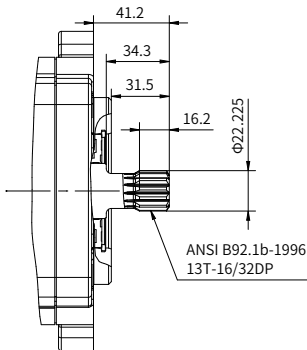

"S1" type spline shaft

# HP3G32 Pump principle

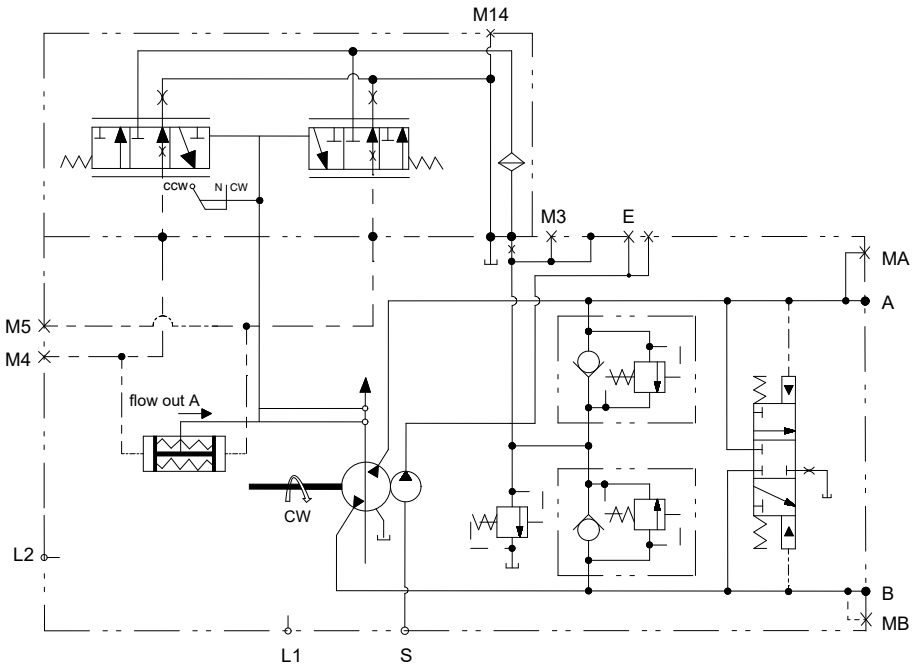

Input shaft rotation	CW		CCW	
Energized coil	C2	C1	C2	C1
Oil port A	In	Out	Out	In
Oil port B	Out	In	In	Out
Servo pressure acting oil port	M5	M4	M5	M4

# Installation size

## HP3G32 Installation size

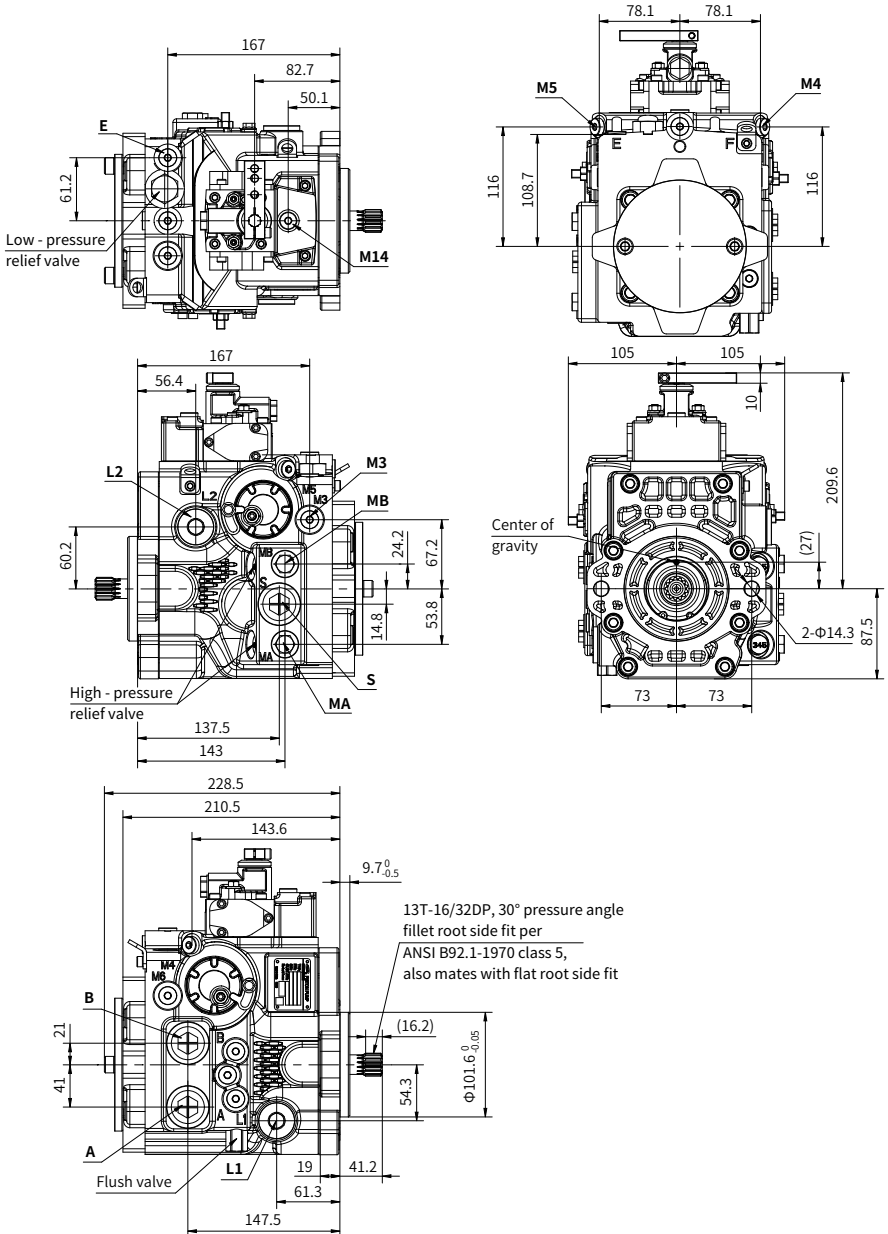

HP3G

## Installation size

### • HP3G32 Port details

	Port Name	Port Size and Description	Tightening Torque(N.m)
S	Suction port	ISO 11926-1 ( 1 1/16-12UN )	101
A, B	Working port	ISO 11926-1 ( 1 1/16-12UN )	101
L1, L2	Drain port	ISO 11926-1 ( 1 1/16-12UN )	101
MA, MB	Port "A" and "B" gage port	ISO 11926-1 ( 9/16-18UNF )	25
M3	Gauge port of charge pump	ISO 11926-1 ( 9/16-18UNF )	25
E	External control port	ISO 11926-1 ( 9/16-18UNF )	25
M4, M5	Servo gage port	ISO 11926-1 ( 7/16-20UNF )	15
M14	Air bleed port	ISO 11926-1 ( 7/16-20UNF )	15

## Installation size

### HP3G32 Mounting Flange

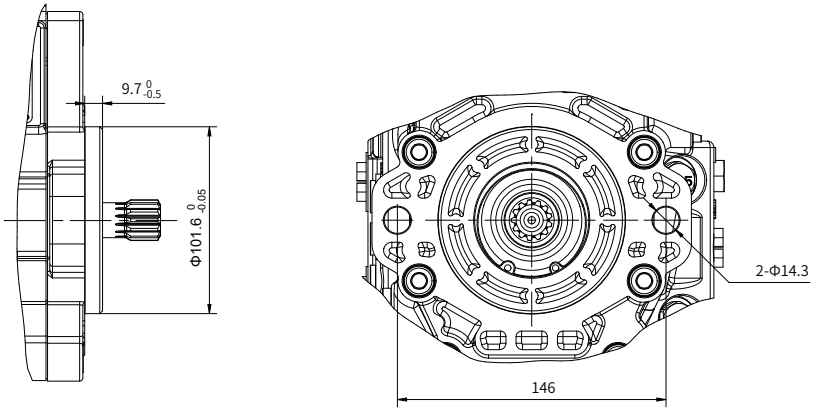

### HP3G32 Input Shaft type

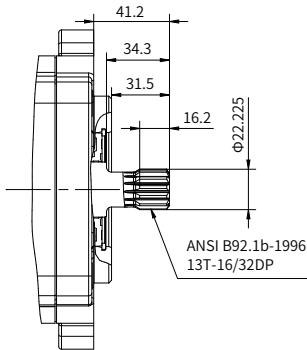

"S1" type spline shaft

# HP3G46 Pump principle

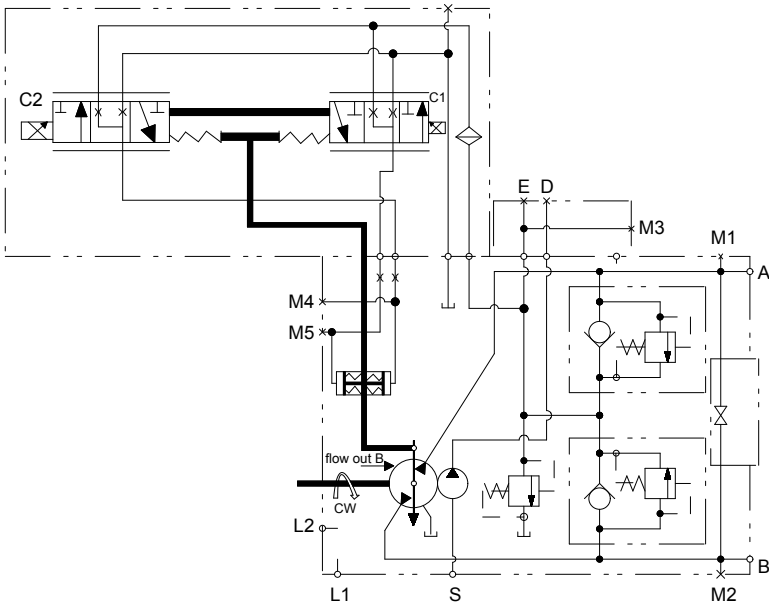

Input shaft rotation	CW		CCW	
Energized coil	C2	C1	C2	C1
Oil port A	In	Out	Out	In
Oil port B	Out	In	In	Out
Servo pressure acting oil port	M5	M4	M5	M4

## Connector:

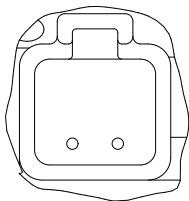

Deutsch DT04-2P  
 Voltage: 12V  
 V View

Refer to pump installation drawing for port locations.



# Installation size

## HP3G46 installation size

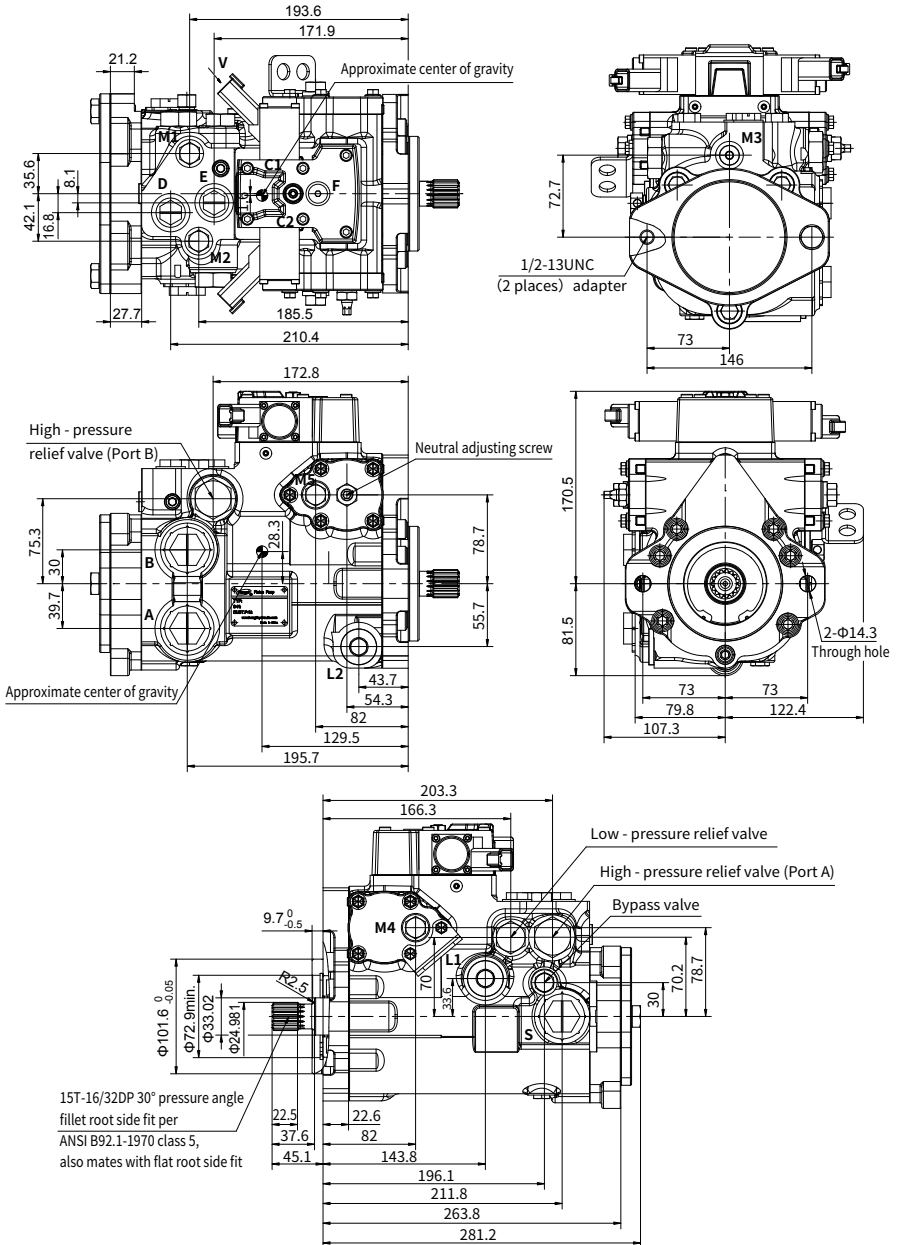

HP3G

## Installation size

### • HP3G46 Port details

	Port Name	Port Size and Description	Tightening Torque(N.m)
S	Suction port	SAE J1926/1 ( 1 5/16-12UN-2B )	134
A, B	Working port	SAE J1926/1 ( 1 5/16-12UN-2B )	134
L1, L2	Drain port	SAE J1926/1 ( 1 1/16-12UN-2B )	101
M1, M2	Port "A" and "B" gage port	SAE J1926/1 ( 9/16-18UNF-2B )	25
M3	Gauge port of charge pump	SAE J1926/1(9/16-18UNF-2B)	25
M4, M5	Servo gage port	SAE J1926/1 ( 9/16-18UNF-2B )	25
D	Charge filtration port D (To remote filter ISO 11926-1 7/8-14 Charge filtration port D charge gauge port for remote filtration with charge pump option)	SAE J1926/1 ( 7/8-14UNF-2B )	73
E	Charge filtration port E (From remote filter charge gauge port for remote filtration with or w/o charge pump option)	SAE J1926/1 ( 7/8-14UNF-2B )	73
F	Air bleed port	SAE J1926/1(7/16-20UNF-2B)	15

## Installation size

### HP3G46 Mounting Flange

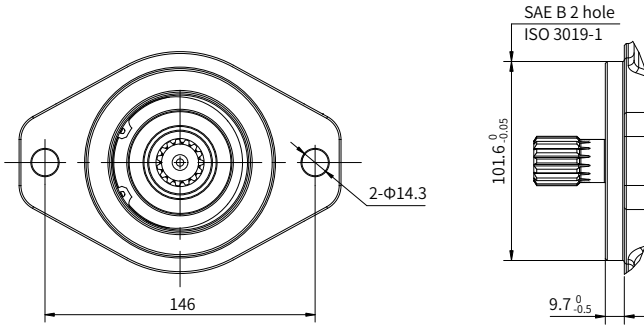

### HP3G46 Input Shaft type

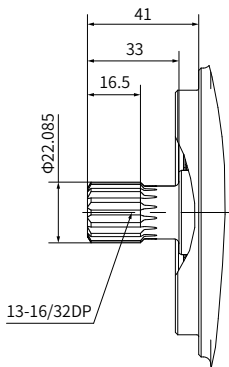

"S1" type spline shaft

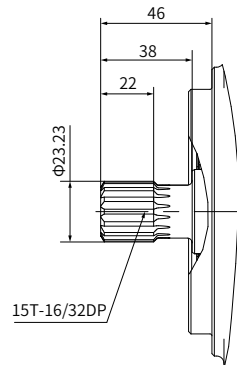

"S2" type spline shaft

**China**

+86 400 101 8889

**America**

+01 630 995 3674

**Germany**

+49 (30) 72088-0

**Japan**

+81 03 6809 1696



© This brochure can be reproduced, edited, reproduced or transmitted electronically without the authorization of Hengli Hydraulic Company. Due to the continuous development of the product, the information in this brochure is not specific to the specific conditions or applicability of the industry, thus, Hengli does not take any responsibility for any incomplete or inaccurate description.