



HP5V SERIES

Swash-plate Type Axial Piston Variable Displacement Pump

HP5V series piston pump is high pressure open circuit axial piston pump specially designed with a new structure, and has lighter weight, higher power density, and longer life compared with HP3V pump.

Apply to open hydraulic circuit

Displacements (cc/rev):	(S)28	28	45	60	76	85	105
Rated pressure (bar):	250	320	320	250	320	280	350
Peaking pressure (bar):	315	350	350	280	350	320	400

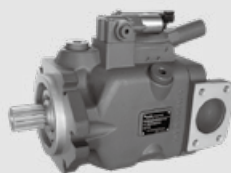

Contents

Technical Data	02
Type introduction	03-05
Regulators introduction	06-12
Installation size	
· HP5VS28 Installation size	13-14
· HP5V28 Installation size	15-16
· HP5V45/60 Installation size	17-18
· HP5V76/85 Installation size	19-21
· HP5V105 Installation size	22-23
· Through Drive Installation Options	24-27

Features

- Variable pump in swash-plate design for open circuit.
- High continuous pressure.
- Exceptional self-priming capability.
- Available with American (SAE) and Japanese (JIS) mounting flanges and shafts.
- Excellent reliability and long life.
- High power to weight ratio.
- Variety of control options.
- Optional through drive.
- Quick control response.
- Low pressure pulsation and low noise.
- Developed for engineering, mobile vehicles, industrial and other industrial application.

Technical Data

Size	HP5VS28	HP5V28	HP5V45	HP5V60	HP5V76	HP5V85	HP5V105	
Displacement (cc/rev)	28	28	45	60	76	85	104.3	
Pressure	Rated pressure (bar)	250	320	320	250	320	280	350
	Peak pressure (bar)	315	350	350	280	350	320	400
Rotation speed	Max for self-priming ¹ (rpm)	3000	3000	2700	2400	2400	2400	2200
	Max ² (rpm)	3600	3600	3250	3000	3000	3000	2600
Weight (Kg)	17.2	20	24	24	28	28	45	
Quantity of oil to fill pump case (L)	0.55	0.6	0.6	0.6	0.8	0.8	1	
Input torque rating (Nm)	198	155	225	225	400	400	530	
Temperature Range (°C)	-20~95							
Viscosity Range (mm ² /s)	10-1000 ³ (The best use of viscosity range 16~36 mm ² /s)							

Permissible through drive torque								
Input shaft code	S1	S2	S3	S4	S5	K1	K2	K3
Input torque rating (Nm)	171	272	552	925	1470	145	230	430

1. Steady state suction pressure should be 0 bar and above(at normal condition);
2. If suction pressure less than 0 bar, Boost pressure should be required;
3. In case of 200-1000mm²/s, please allow system to warm up before using machine.

Type introduction

HP5V	76	/	A	V	1	O	R	B2	S1	M	S	—	L1/1	—	D	2	—	T
①	②		③	④	⑤	⑥	⑦	⑧	⑨	⑩	⑪		⑫		⑬	⑭		⑮

Product series

①	Product series	HP5V
	Compact product series	HP5VS

Displacement

②	Displacement	cc/rev	28	45	60	76	85	105
---	--------------	--------	----	----	----	----	----	-----

Design series

③	Design series	A Series	A
---	---------------	----------	---

Seals

④	Seals	FKM (Viton rubber: DIN ISO 1629)	V
		NBR (Nitrile rubber :DIN ISO 1629)	N

Hydraulic circuit

⑤	Hydraulic circuit	Open circuit	1
---	-------------------	--------------	---

Through Drive

		S28	28	45	60	76	85	105	Code	
⑥	Without through drive	●	●	●	●	●	●	●	O	
	Without through drive, SAE flange ports, rear	●	○	●					NO1	
	Without through drive, Thread ports, rear			●					NO2	
	Standard configuration with gear pump 6cc/rev			●	●	●	●	○	X1	
	Standard configuration with gear pump 10cc/rev			○	○	○	○	○	X2	
	Mounting Flange	Spline shaft								
	SAE A 82-2	SAE J744-16-4 9T 16/32DP		●	●	●	●	●	●	A1
		SAE J744-19-4 11T 16/32DP			○	○	●	●	●	A2
	SAE B 101-2	SAE J744-22-4 13T 16/32DP	○	●	●	●	●	●	●	B1
		SAE J744-25-4 15T 16/32DP			●	●	●	●	●	B2
	SAE C 127-2	SAE J744-32-4 14T 12/24DP					●	●	○	C1
		SAE J744-38-4 17T 12/24DP							○	C2
SAE C 127-4	SAE J744-32-4 14T 12/24DP					●	●	●	C3	
	SAE J744-38-4 17T 12/24DP							●	C4	

Type introduction

Direction of Rotation

⑦	Viewed on drive shaft	Clockwise	R
		Counter-clockwise	L

Input Mounting flanges

⑧	Mounting flanges size	S28	28	45	60	76	85	105	Code
	SAE B 101-2	●	●	●	●				
SAE C 127-2						●	●	●	C2
SAE C 127-4						●	●	●	C4

Input Shaft

⑨	Shaft size	S28	28	45	60	76	85	105	Code
	SAE J744-22-4 13T 16/32DP	●	●	●	●	○	○		
SAE J744-25-4 15T 16/32DP			●	●	●	●			S2
SAE J744-32-4 14T 12/24DP						●	●	●	S3
SAE J744-38-4 17T 12/24DP								●	S4
SAE J744-44-4 13T 8/16DP								●	S5
SAE J744-22-1 B6.35×28 straight shaft	●	●							K1
SAE J744-25-1 B6.35×32 straight shaft			●	●					K2
SAE J744-32-1 B7.94×44 straight shaft						●	●		K3

Thread type of Flange Fixing Port

⑩	Thread type	Metric threads	M
		UNC threads	S

Connection type (except inlet and outlet port)

⑪	UNC port, ISO 11926	A
	BSPPG thread, JIS B2351	G
	Metric port, ISO 9974	M

Type introduction

Control type

Control type		S28	28	45	60	76	85	105	Code	
⑫	Apply to constant displacement pump	○	○	○	○	○	○	○	N	
	Pressure cut-off	Only pressure control	●	●	●	●	●	●	○	DR
		Electro-hydraulic pressure control, positive control	○	○	○					ER1
		Electro-hydraulic pressure control, negative control	●	●	●	●	●	●	●	ER2
		+Load sensing	●	●	●	●	●	●	○	L1
		Remotely operated	●	●	●	●	●	●	○	P0
	Power Control	Pressure cut-off+ Load sensing	●		●	●	●	●	●	L1/1
		Remotely operated+ Load sensing	●		●	●	●	●	○	P0/1
		Electrically (negative control)	●				●	●	○	L1/1-E0
		+Pressure cut-off+ Load sensing					●	●	○	L1/1-H0
		+Load sensing		●						LP1

Connector for solenoids

Connector for solenoid		S28	28	45	60	76	85	105	Code
⑬	Without solenoid	●	●	●	●	●	●	●	Blank
	AMP Junior timer; 2 contact pin, (without suppressor diode)					●	●	○	A
	Deutsch DT04-2P; 2 contact pin, (without suppressor diode)	●	●	●	●	●	●	●	D

Input Voltage

Without solenoid		Code
⑭	12VDC	1
	24VDC	2

Application Conditions

Application		S28	28	45	60	76	85	105	Code
⑮	Apply to excavator	●	●	●	●	●	●	●	T
	Other mobile machinery, construction machinery, industrial application	●	●	●	●	●	●	●	Blank

Remark: ● = available; ○ = On request;

Regulators introduction

Code: L1(DR)

Control Type :

- 1. Load sensing**
Standard setting: 15bar
Adjustment range: 10bar-21bar
- 2. Pressure Cut-off**
Standard setting: 320bar
Adjustment range: 21bar-320bar

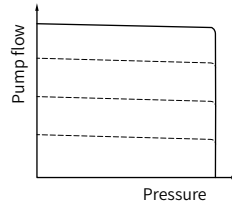

Function and Features: Load sensing + Pressure Cut-off

The load sensing control is a flow control option that operates as a function of the load pressure to regulate the pump displacement to match the actuator flow requirement. The load sensing control compares pressure before and after the sensing orifice and maintains the pressure drop across the orifice (differential pressure Δp) and with it the pump flow constant.

If the differential pressure Δp increases, then the pump displacement decreases, and if the differential pressure Δp decreases, then the pump displacement increases until the pressure drop across the sensing orifice in the valve is restored.

$$\Delta p = P_p - P_l$$

Pump displacement is controlled to match the flow requirement as a function of the system differential pressure (load pressure vs delivery pressure). In addition, there is a pressure cut off function incorporated into the control.

The pressure cut off control keeps the pressure in a hydraulic system constant within its control range even under varying flow conditions, the variable pump only moves as much hydraulic fluid as is required by the actuators. If the operating pressure exceeds the set point set at the pressure control valve, the pump displacement is automatically swivelled back until the pressure deviation is corrected.

"DR" control is on the basis of "L1" control, tighten the load sensitive valve adjust screw, and the load sensitive valve doesn't work.

Hydraulic Circuit:

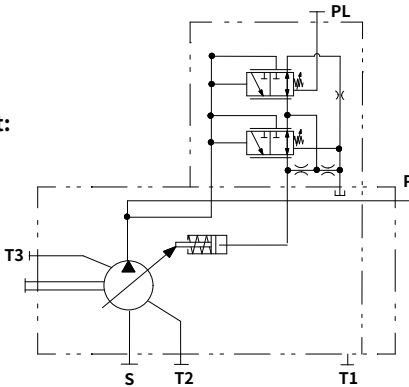

Regulators introduction

Code: P0

Control Type :

- 1. Load sensing**
Standard setting:15bar
Adjustment range:10bar-21bar
- 2. Pressure Cut-off**
Standard setting:320bar
Adjustment range:21bar-320bar

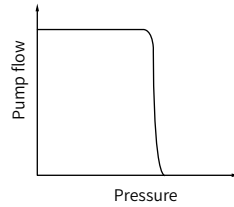

Function and Features: P0 Pressure cut-off

The Pressure Cut-off regulator monitors outlet pressure once the pressure reaches the cut-off setting, the pump will return to minimum displacement.

Remote Control

The pump can be remotely controlled by connecting a relief valve to the PL port of the regulator. The pump can also unload at a low pressure continue standby condition by using a solenoid valve.

Hydraulic Circuit:

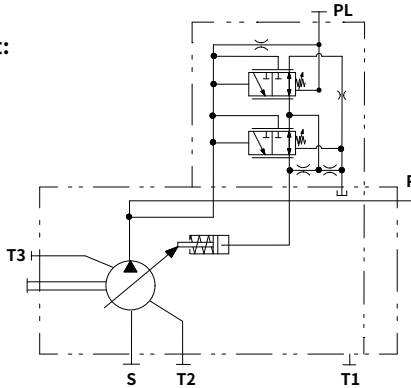

HPSV

Regulators introduction

Code: □ /1

Control Type :

- 1. Load sensing**
Standard setting: 15bar
Adjustment range: 10bar-21bar
- 2. Pressure Cut-off**
Standard setting: 320 bar
Adjustment range: 21 bar-320 bar
- 3. Torque limiting**

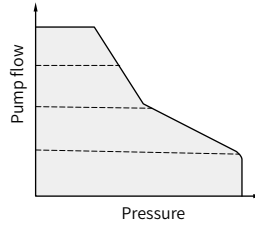

Function and Features: _/1 Load Sense and Pressure Cut-off with Torque limiting

The L1 control functions as previously noted. In response to a rise in delivery pressure the swash plate angle is decreased, restricting the input torque. This regulator prevents excessive load against the prime mover.

The torque limit control module is comprised of two springs that oppose the spool force by the system pressure. By turning an outer and inner spring adjustment screw, the appropriate input torque limit can be set.

Hydraulic Circuit:

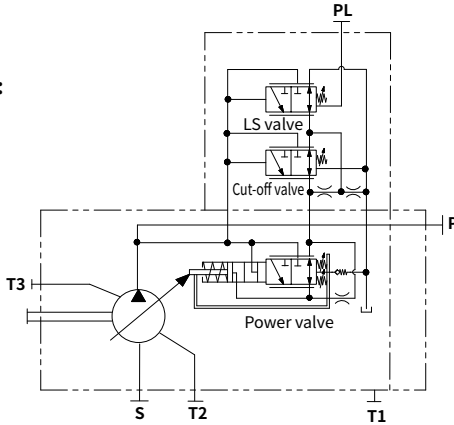

Regulators introduction

Code:

□ /1-E0

Control Type :

- 1. Load sensing**
Standard setting:15bar
Adjustment range:10bar-21bar
- 2. Pressure Cut-off**
Standard setting: 320bar
Adjustment range: 21bar-320bar
- 3. Port Pr pressure:** 20bar~45bar
- 4. Electromagnet characters**

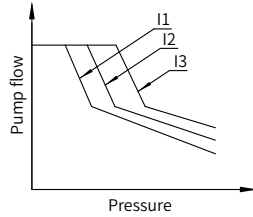

Voltage(V)	Current(A)	Resistance(Ω)	Insulation grade
12	0.80	7.3±10%(20°C)	H(180°C)
24	0.75	21.2±10%	UP to IP6K6/IPX9K

5. Connector (deutsch or Amp)
DEUTSCH: DT04-2P-E005
AMP: 174354-2 , 173706-1

Function and Features:

/1-E0 Load Sense and Pressure Cut-off with Torque limiting

The L1 control functions as previously noted. It controls the input torque of the pump by changing different current, specific current is related to certain input torque, thus satisfy needs of different torque on excavator

Hydraulic Circuit:

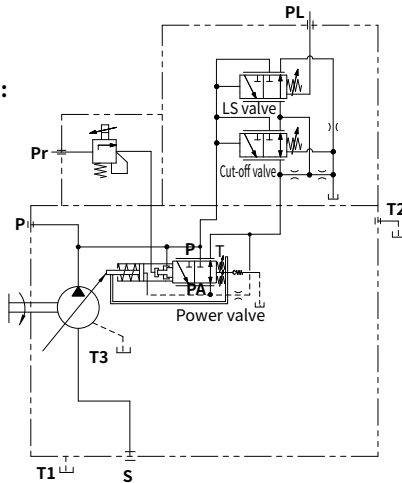

Regulators introduction

Code: /1-H0

Control Type :

- 1. Load sensing**
Standard setting:15bar
Adjustment range:10bar-21bar
- 2. Pressure Cut-off**
Standard setting: 320bar
Adjustment range: 21bar-320bar
- 3. Port Pr pressure: 0bar~39bar**

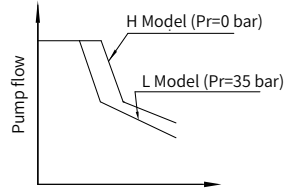

Function and Features: /1-H0 Load Sense and Pressure Cut-off with Total torque limiting

The L1 control functions as previously noted. It controls the input torque of the pump by changing different input pressure of port Pr, specific current is related to certain input torque, thus satisfy needs of different torque on excavator.

Hydraulic Circuit:

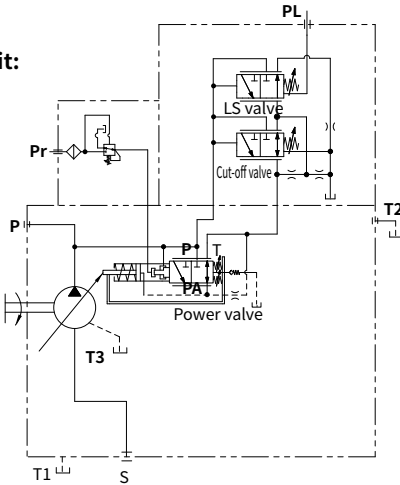

Regulators introduction

Code: LP1

- Control Type:**
1. Load sensing
Standard setting: 17bar
Adjustment range:13bar~17bar
 2. Torque limiting

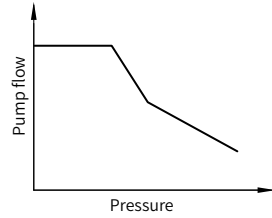

Function and Features: /1 Load Sense and Pressure Cut-off with Torque limiting

The L1 control functions as previously noted. In response to a rise in delivery pressure the swash plate angle is decreased, restricting the input torque. This regulator prevents excessive load against the prime mover.

The torque limit control module is comprised of two springs that oppose the spool force by the system pressure. By turning an outer and inner spring adjustment screw, the appropriate input torque limit can be set.

Hydraulic Circuit:

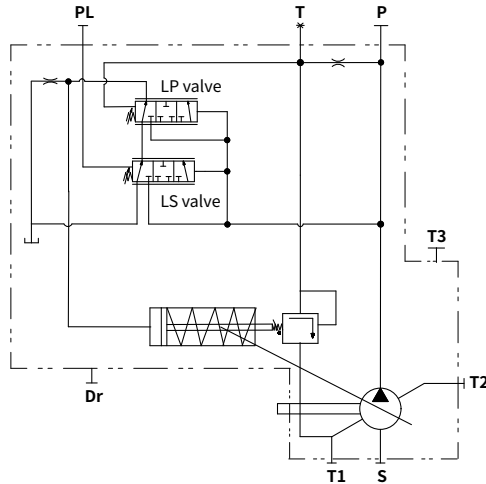

HPSV

Regulators introduction

Code: ER2

Control Type : Electro-hydraulic pressure control

The ER2 valve is set to a certain pressure by a specified variable solenoid current.

This causes an increase or decrease in the pump swivel angle (flow) in order to maintain the electrically set pressure level. The pump thus only delivers as much hydraulic fluid as the consumers can take. The desired pressure level can be set steplessly by varying the solenoid current.

As the solenoid current signal drops towards zero, the pressure will be limited to P_{max} by an adjustable hydraulic pressure cut-off to secure fail safe function

Static current-pressure characteristic curve ER2

(negative characteristic curve measured with pump in zero stroke)

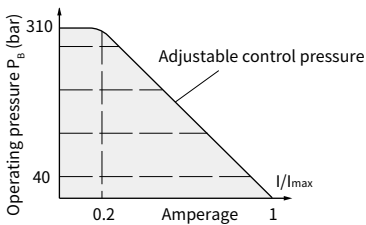

- Hysteresis static < 3 bar

Circuit diagram:

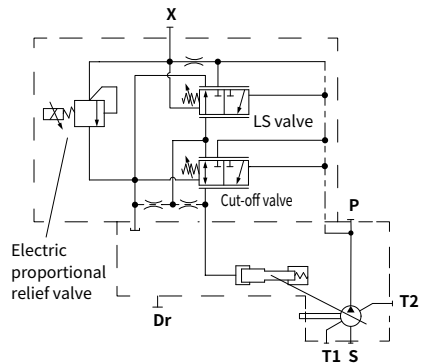

Flow-pressure characteristic curve

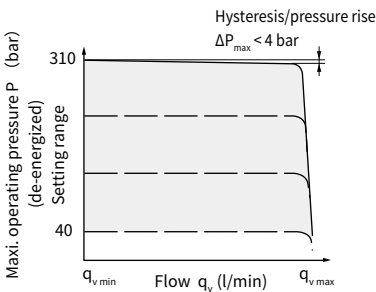

- Characteristic curves valid for $n_1 = 1500 \text{ rpm}$ and $t_{\text{fluid}} = 50^\circ \text{C}$.

Technical data, solenoid		
Voltage		24 V ($\pm 20\%$)
Control current	Start of control at p_{max}	50 mA
	End of control at p_{min}	600 mA
Limiting current		0.77 A
Nominal resistance (at 20°C)		22.7 Ω
Dither frequency		100 ~ 200 Hz
Actuated time		100%
Operating temperature range at valve		-20°C to $+115^\circ \text{C}$

Installation size

HP5VS28 installation size

Displacement is adjustable
 HP5VS28 with Cut-off/Load Sense Control with torque limit
 (Clockwise Rotation)
 For the CCW pump just reverse the inlet and outlet port.

HPSV

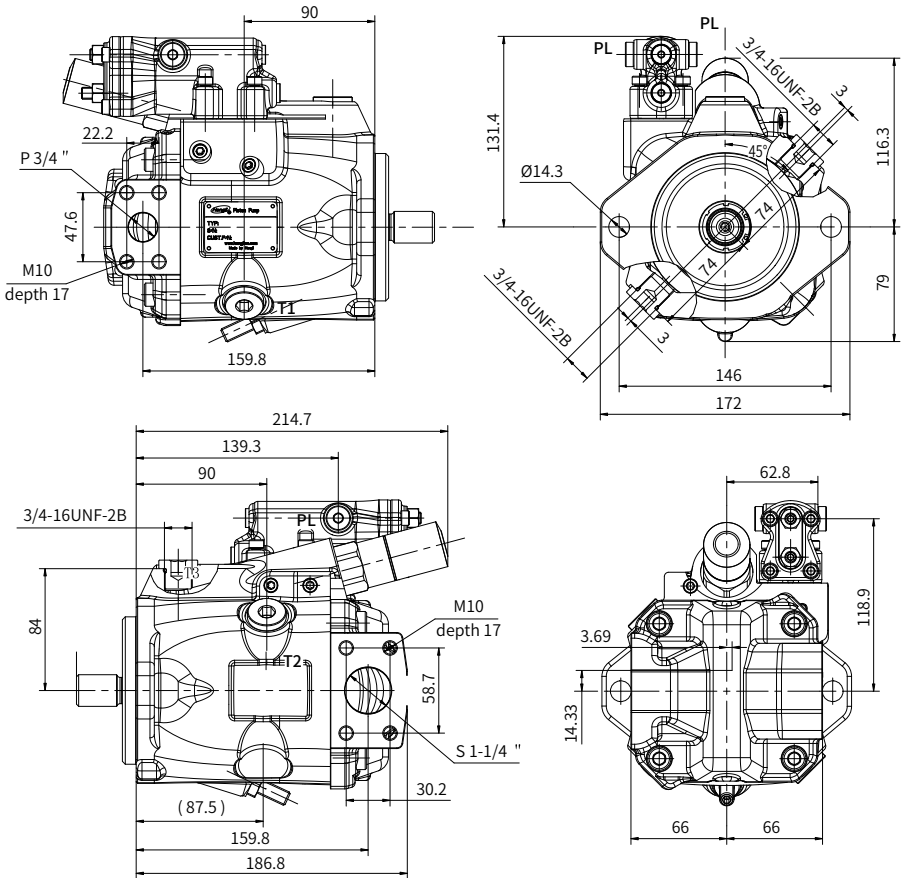

Port Details

Port Name	Port Size and Description	Tightening Torque (N-m)		
			P	Working port
		S(UNC) 3/8-16UNC-2B (depth 17mm)		
S	Suction port	1-1/4"SAE J518C code 61 (3000psi)	M(metric) M10×1.5 (depth 17mm)	57
			S(UNC) 7/16-16UNC-2B (depth 17mm)	
T1, T2, T3	Case drain port	ISO 11926 (3/4"-16UNF-2B)		98
PL	LS Control port	ISO 11926 (7/16"-20UNF-2B)		12

Installation size

HP5VS28 Mounting Flange

HP5V

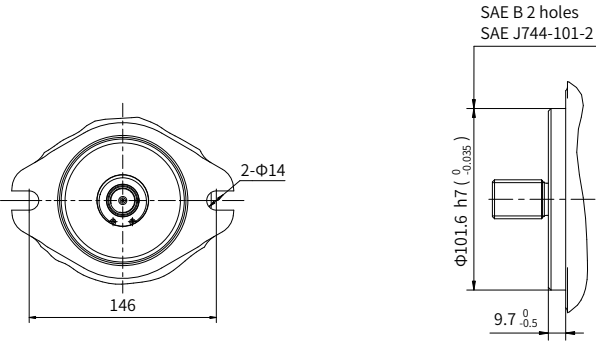

SAE "B2" type

HP5VS28 Input Shaft type

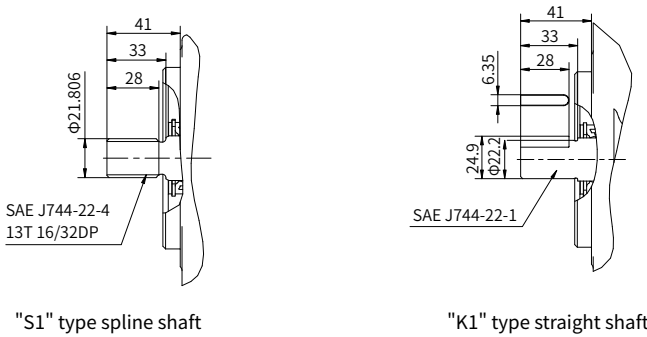

"S1" type spline shaft

"K1" type straight shaft

Installation size

HP5V28 installation size

Displacement is adjustable
 HP5V28 with Cut-off/Load Sense Control with torque limit
 (Clockwise Rotation)
 For the CCW pump just reverse the inlet and outlet port.

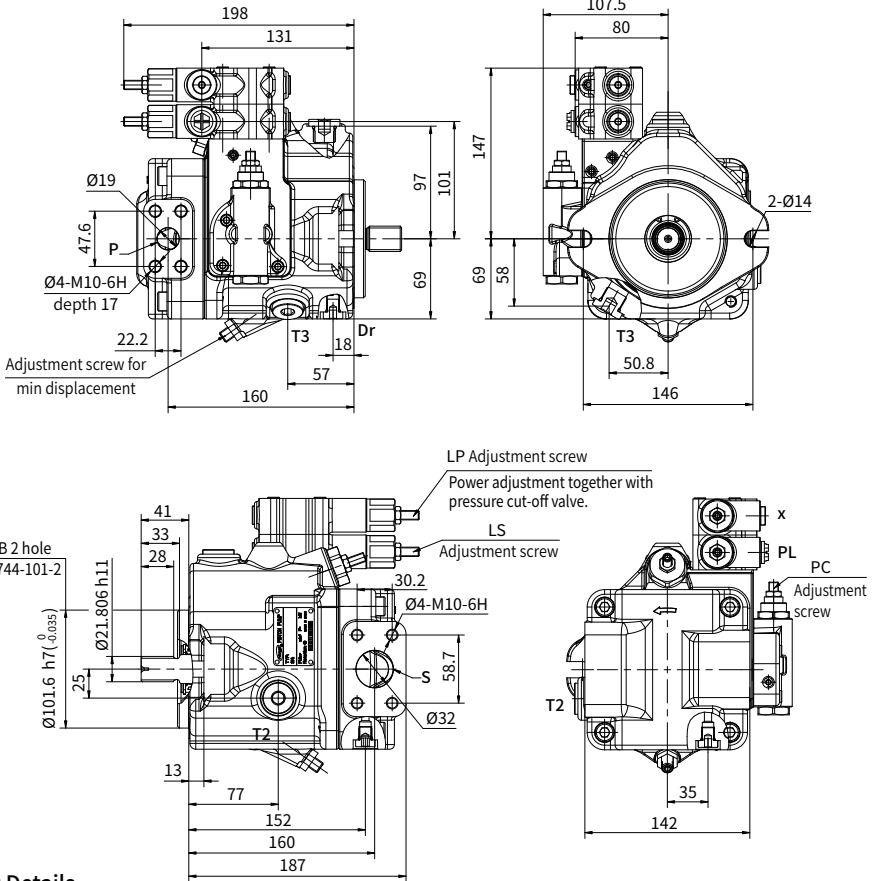

Port Details

Port Name		Port Size and Description			Tightening Torque (N-m)
P	Working port	3/4"SAE J518C code 61 (5000psi)	M(metric)	M10×1.5 (depth 17mm)	57
			S(UNC)	3/8-16UNC-2B (depth 17mm)	
S	Suction port	1-1/4"SAE J518C code 61 (3000psi)	M(metric)	M10×1.5 (depth 17mm)	57
			S(UNC)	7/16-16UNC-2B (depth 17mm)	
T1、 T2、 T3	Case drain port	SAE J1926/1 (3/4-16UNF-2B) depth 16mm			98
PL	LS Control port	G 1/4, depth 12mm			12
Dr	Air bleed port	SAE J1926/1 (7/16-20UNF-2B) depth11.5mm			12

Installation size

HP5V28 Mounting Flange

HP5V

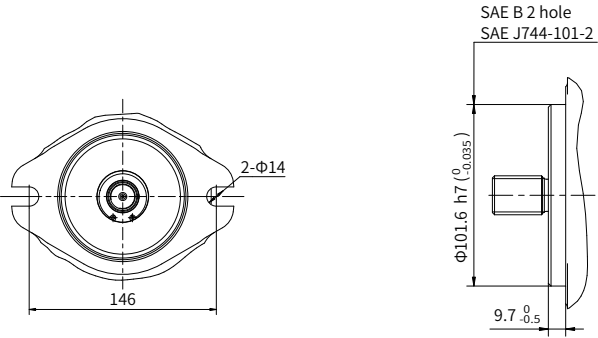

SAE "B2" type

HP5V28 Input Shaft type

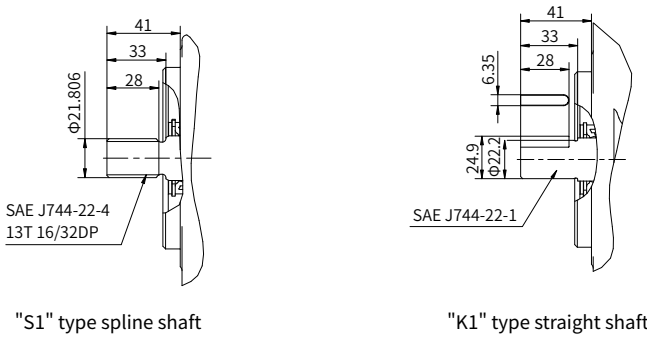

"S1" type spline shaft

"K1" type straight shaft

Installation size

HP5V45/60 Installation size

HP5V45/60 with Cut-off/Load Sense Control with torque limit (Clockwise Rotation)

For the CCW pump just reverse the inlet and outlet port.

HPSV

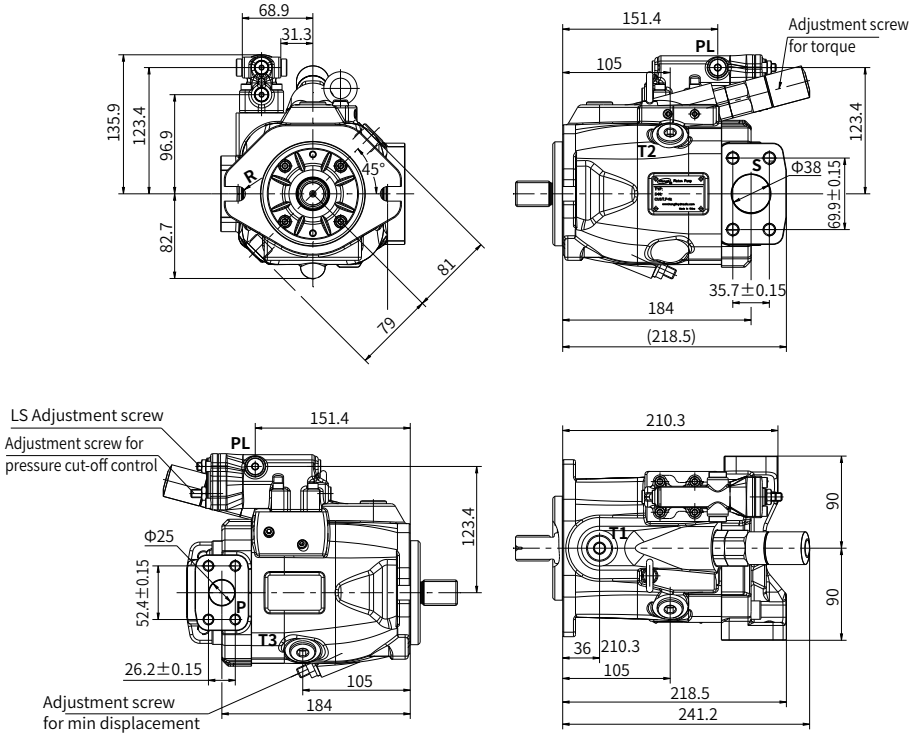

Port Details

	Port Name	Port Size and Description			Tightening Torque (N-m)
P	Working port	1"SAE J518C Code 61 (5000psi)	M (metric)	M10×1.5 (depth 17mm)	57
			S(UNC)	3/8-16UNC-2B (depth 17mm)	
S	Suction Port	1-1/2"SAE J518C Code 61 (3000psi)	M (metric)	M12×1.75(depth 20mm)	98
			S(UNC)	1/2-13UNC-2B (depth 20mm)	
T1、 T2、 T3	Case drain Port	ISO 11926 (7/8-14UNF-2B) depth 13mm			120
PL	LS Control Port	ISO 11926 (7/16-20UNF-2B) depth 11.5mm			12

Installation size

HP5V45/60 Mounting Flange

HP5V

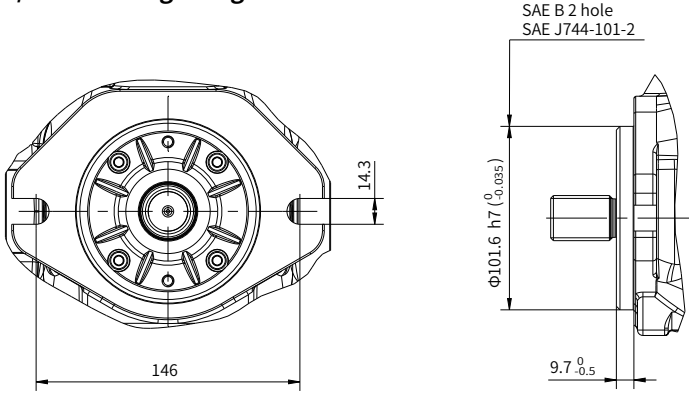

SAE "B2" type

HP5V45/60 Input Shaft type

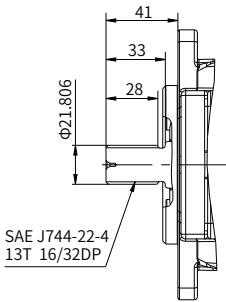

"S1" type spline shaft

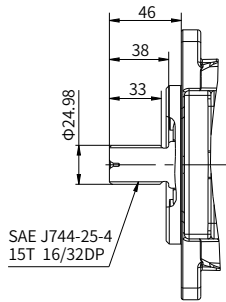

"S2" type spline shaft

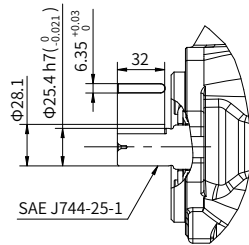

"K2" type straight shaft

Installation size

HP5V76/85 installation size
 HP5V76/85 with Cut-off/Load Sense Control with torque limit (Clockwise Rotation)
 For the CCW pump just reverse the inlet and outlet port.

HPSV

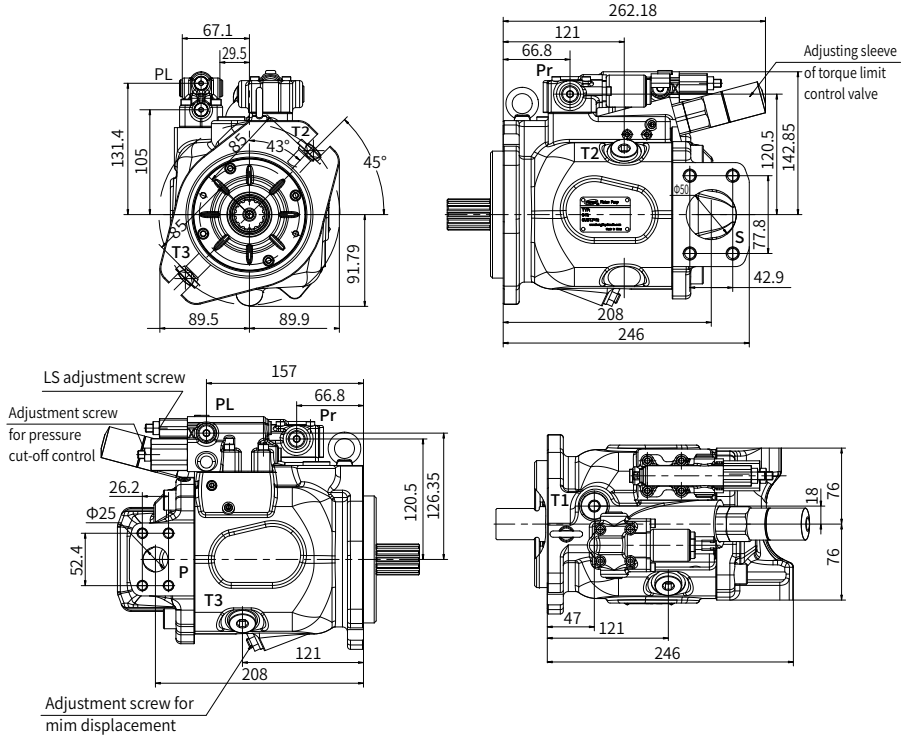

Port Details

	Port Name	Port Size and Description			Tightening Torque (N-m)
P	Working port	1"SAE J518C	M (metric)	M10×1.5 (depth 17mm)	57
		Code 61 (5000psi)	S(UNC)	3/8-16UNC-2B (depth 17mm)	
S	Suction Port	2"SAE J518C	M (metric)	M12X1.75 (depth 20mm)	98
		Code 61 (3000psi)	S(UNC)	1/2-13UNC-2B (depth 20mm)	
T1、T2、T3	Case drain Port	SAE J1926/1 (3/4-16UNF-2B) (depth 16 mm)			98
PL	LS Control Port	SAE J1926/1 (7/16-20UNF-2B) (depth 11.5mm)			12
Pr	Electronic control or Hydraulic control pilot	SAE J1926/1 (7/16-20UNF-2B) depth 11.5mm			12

Installation size

HP5V76/85 Mounting Flange

HP5V

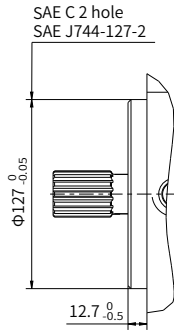
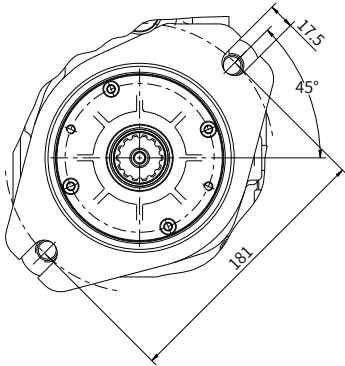

SAE "C2" type

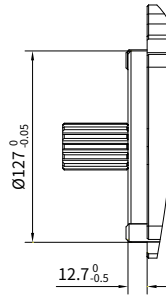
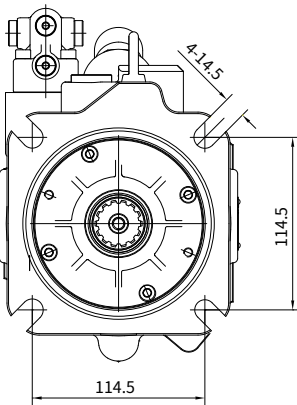

SAE "C4" type

Installation size

HP5V76/85 Input Shaft type

HPSV

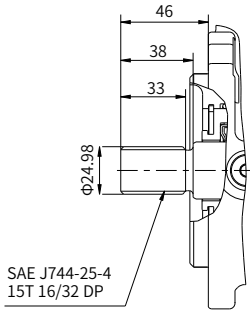

"S2" type spline shaft

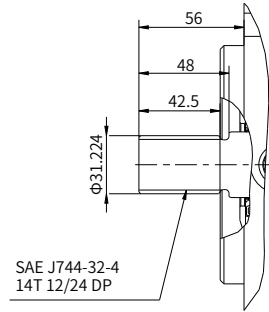

"S3" type spline shaft

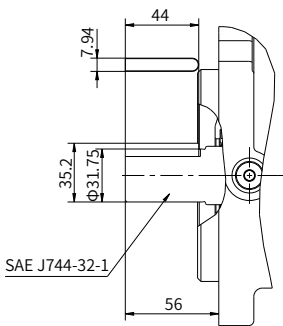

"K3" type straight shaft

Installation size

HP5V105 Installation size

HP5V105 with Cut-off/Load Sense Control with torque limit
(Clockwise Rotation)
For the CCW pump just reverse the inlet and outlet port.

HP5V

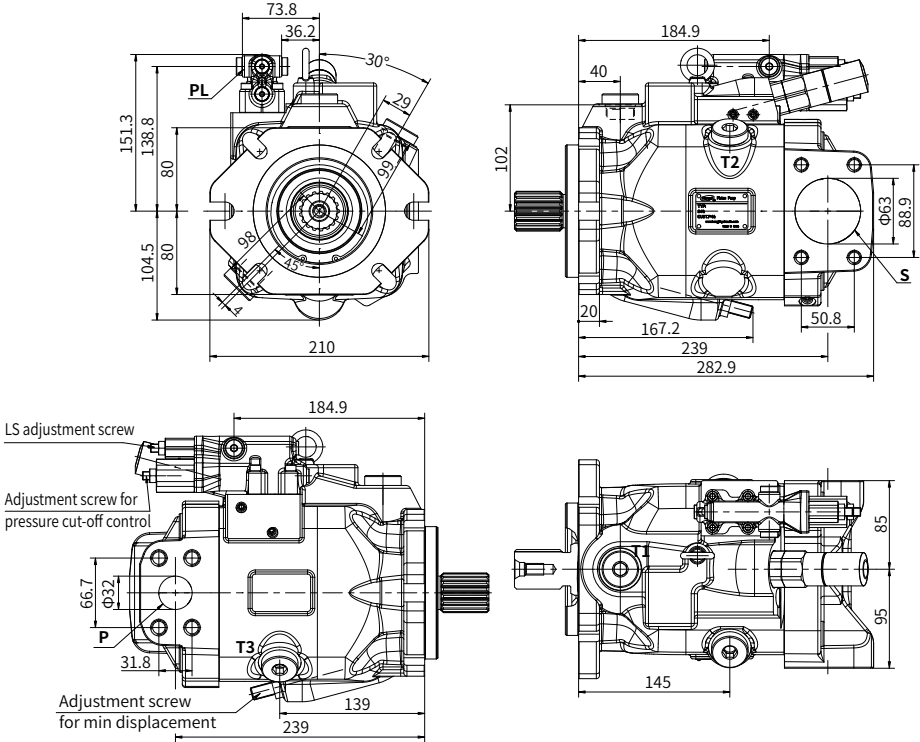

Port Details

	Port Name	Port Size and Description			Tightening Torque (N-m)
P	Working port	1 1/4"SAE J518C code 62 (5000psi)	M (metric)	M14×2 (depth 19mm)	157
			S(UNC)	1/2-13UNC-2B (depth 22mm)	
S	Suction Port	2 1/2"SAE J518C code 61 (2500psi)	M (metric)	M12×1.75 (depth 17mm)	98
			S(UNC)	1/2-13UNC-2B (depth 22mm)	
T1	Case drain port	SAE J1926/1 (1 1/16-12UN-2B depth 15mm)			167
PL	LS Control port	SAE J1926/1 (7/16-20UNF-2B depth 15mm)			12
T2, T3	Ail Bleed port	SAE J1926/1 (1 1/16-12UN-2B depth 15mm)			167

Installation size

HP5V105 Mounting Flange

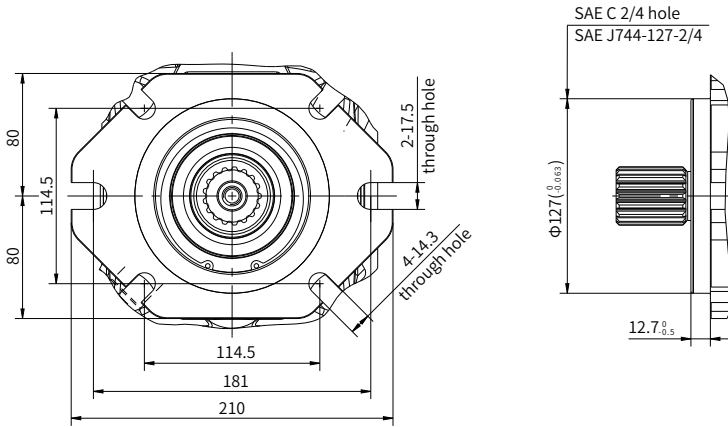

HPSV

HP5V105 Input Shaft type

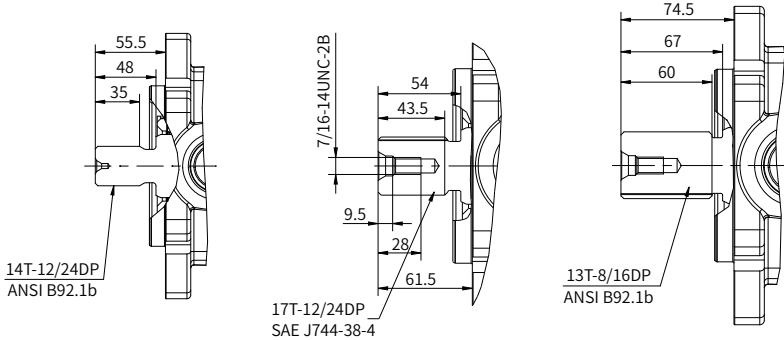

"S3" type spline shaft

"S4" type spline shaft

"S5" type spline shaft

Through Drive Installation Options

A1 Type

SAE A 82-2 + SAE J744-16-4 9T 16/32DP

HP5V

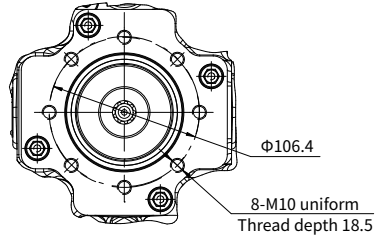
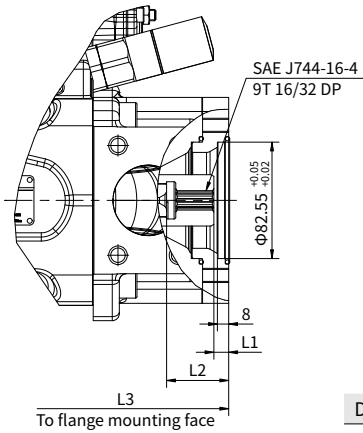

Disp. (cc/rev)	28	45/60	76/85	105
L1	8	12	10.5	14.5
L2	34	37.5	44	44.5
L3	204	226	265	307

A2 Type

SAE A 82-2 + SAE J744-19-4 11T 16/32DP

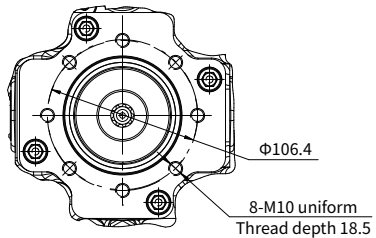
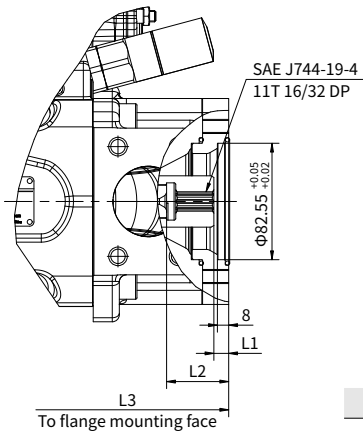

Disp. (cc/rev)	76/85	105
L1	10.5	14.5
L2	44	44.5
L3	265	307

Through Drive Installation Options

B1 Type

SAE B 101 -2 + SAE J744-22-4 13T 16/32DP

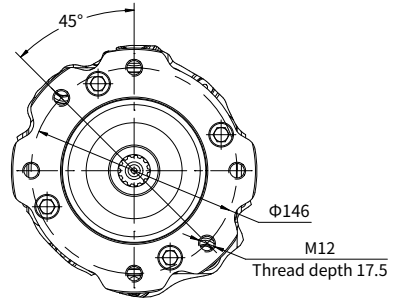
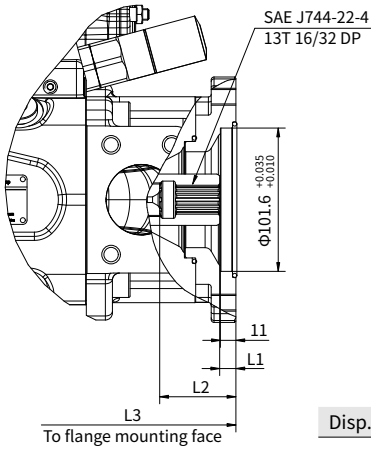

Disp. (cc/rev)	28	45/60	76/85	105
L1	11	11.2	11.5	11.5
L2	50.5	52.4	54	51
L3	224	250.5	275	314

B2 Type

SAE B 101 -2 + SAE J744-25-4 15T 16/32DP

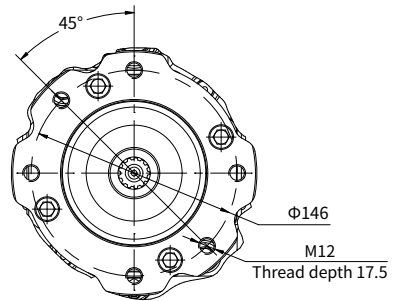
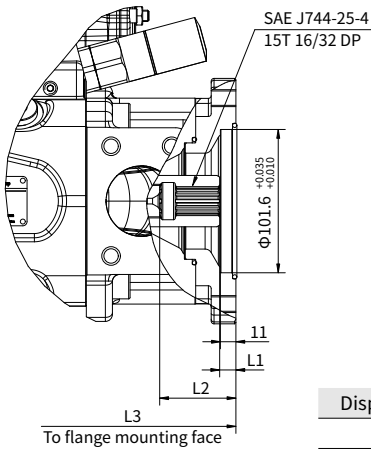

Disp. (cc/rev)	45/60	76/85	105
L1	11.2	11.5	11.5
L2	52.4	54	51
L3	250.5	275	314

Through Drive Installation Options

C1 Type

SAE C 127-2 + SAE J744-32-4 14T 12/24DP

HP5V

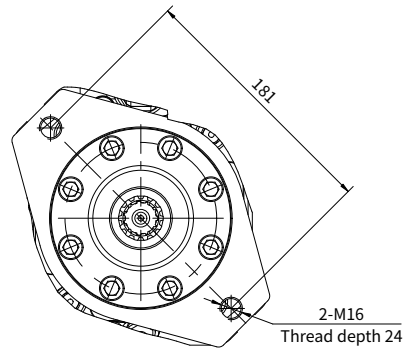
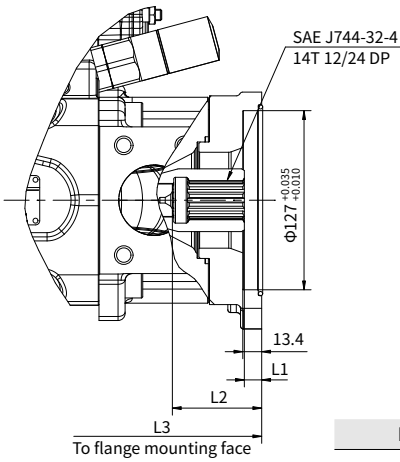

Disp. (cc/rev)	76/85
L1	11.5
L2	62.5
L3	283.5

C2 Type

SAE C 127-2 + SAE J744-38-4 17T 12/24DP

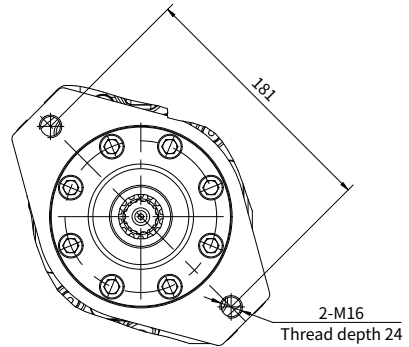
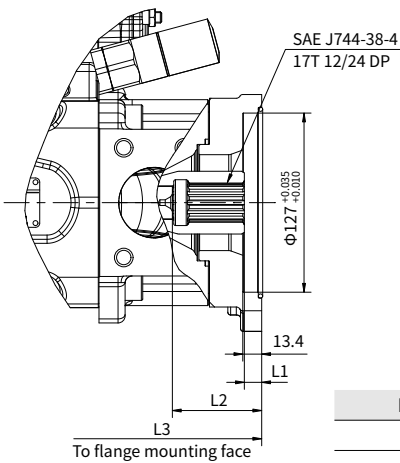

Disp. (cc/rev)	105
L1	13
L2	64.5
L3	326.5

Through Drive Installation Options

C3 Type

SAE C 127-4 + SAE J744-32-4 14T 12/24DP

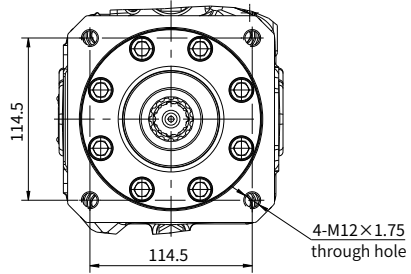
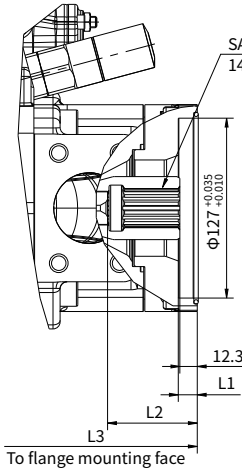

Disp. (cc/rev)	76/85	105
L1	13.4	14
L2	63.3	59
L3	284.3	321.5

C4 Type

SAE C 127-4 + SAE J744-38-4 17T 12/24DP

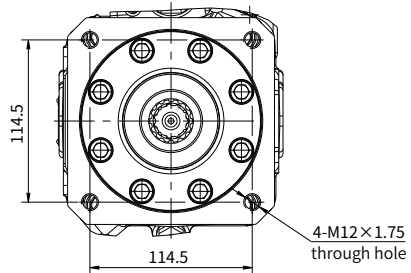
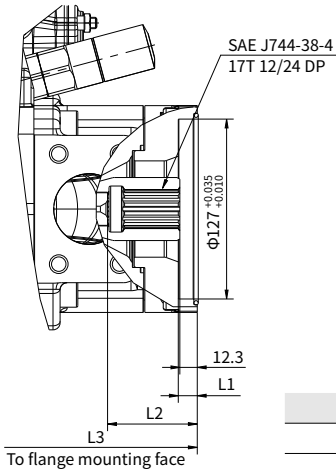

Disp. (cc/rev)	105
L1	13
L2	64.5
L3	326.5

China

+86 400 101 8889

America

+01 630 995 3674

Germany

+49 (30) 72088-0

Japan

+81 03 6809 1696



© This brochure can be reproduced, edited, reproduced or transmitted electronically without the authorization of Hengli Hydraulic Company. Due to the continuous development of the product, the information in this brochure is not specific to the specific conditions or applicability of the industry, thus, Hengli does not take any responsibility for any incomplete or inaccurate description.